



CITY OF OTHELLO

PUBLIC WORKS DESIGN STANDARDS 2021

Adopted by City Council on APRIL 12, 2021

City of Othello Public Works Standards, 2021

Page 1 of 96

MAYOR

SHAWN LOGAN

CITY COUNCIL

GENNA DOROW

JON ERICKSON

COREY EVERETT

ANGEL GARZA

JOHN LALLAS

MARIA QUEZADA

MARK SNYDER

CITY ADMINISTRATOR

SHAWN LOGAN

CITY ATTORNEY

KELLY E. KONKRIGHT

CITY ENGINEER

SHAWN O'BRIEN

PUBLIC WORKS DIRECTOR

TERRY CLEMENTS

TABLE OF CONTENTS

INTRODUCTION AND REFERENCES. 4

CONSTRUCTION REQUIREMENTS8

DEVIATION PROCEDURES 12

DIVISION 1 GENERAL REQUIREMENTS.....14

DIVISION 2 EARTHWORK39

DIVISION 4 BASES 46

DIVISION 5 SURFACE TREATMENTS AND PAVEMENTS46

DIVISION 6 STRUCTURES52

DIVISION 7 DRAINAGE STRUCTURES, STORM SEWERS, SANITARY SEWERS,
WATER MAINS, AND CONDUIT.53

DIVISION 8 MISCELLANEOUS CONSTRUCTION..... 76

DIVISION 9 MATERIALS. 83

PUBLIC WORKS DESIGN STANDARD CONSTRUCTION DETAILS

INTRODUCTION AND REFERENCES

All construction within any right-of-way or municipal easement, or connection to an existing City utility or storm drainage system, or extension of private water and sewer mains and appurtenances on private property shall comply with the 2020 edition of the Washington State Department of Transportation (WSDOT) Standard Specifications for Road, Bridge, and Municipal Construction as revised by these City of Othello Public Works Design Standards. WSDOT amendments to the 2020 Standard Specifications for Road, Bridge, and Municipal Construction are explicitly excluded by the Public Works Design Standards except as specifically written or revised by the City of Othello. All construction shall conform to the applicable standards in effect at time of Construction Plan approval, or when the permit is issued if no Construction Plans are required. Construction plan approval shall expire one year after approval date if construction has not started; however, if Construction Plans are approved in conjunction with platting processes, the Construction Plans shall expire concurrently with the preliminary plat. All revisions contained in the City of Othello Public Works Design Standards shall prevail over other specifications unless revised in writing by the City, and except for project-specific Special Provisions that have been approved by the City Engineer.

All revised specifications described herein conform to similar section numbers as listed in the 2020 Standard Specifications for Road, Bridge, and Municipal Construction. Reference materials for modification are compiled into the City of Othello Public Works Design Standards from APWA Specifications, Federal regulations, Washington State statutes and regulations, Othello ordinances or resolutions, recommended standards for water works, recommended standards for sewage works, Othello engineering recommendations, International Building Codes, and the Current Manual on National Manual on Uniform Traffic Control Devices (MUTCD).

All construction subject to the Public Works Design Standards shall be constructed to ensure conformity within the existing block unless construction that deviates from this requirement is approved by the Engineer in writing prior to construction. Water, sewer, and street construction shall be in substantial compliance with the Water, Sewer, Street, and other Comprehensive Plans or Capital Improvement Plans that are in effect at the time of Construction Plan approval.

Any discrepancies noted between the Special Provisions, the Public Works Design Standards, and the Standard Specifications shall be resolved in accordance with Section 1-04.2. Furthermore, any discrepancy shall be brought to the attention of the Engineer.

Materials and methods not provided for in the Public Works Design Standards may be allowed to be used if the applicant demonstrates to the City of Othello that the materials and methods proposed are equal to or superior to the Public Works Design Standards. Deviation from the standards shall be granted or denied solely at the discretion of the City Council or the City Engineer.

The City of Othello *Public Works Design Standards* and the 2020 edition of the WSDOT *Standard Specifications for Road, Bridge, and Municipal Construction* are on file at the Engineering Department, 500 East Main Street, Othello, WA, where they may be examined and consulted by any interested party.

The City of Othello *Public Works Design Standards* are also available for purchase from the Engineering Department, and they are available on the Internet at <https://www.othellowa.gov>.

The *2020 Standard Specifications for Road, Bridge and Municipal Construction* are available for purchase from the Washington State Department of Transportation, Olympia, Washington.

PROLOG

The Mayor and Council of the City of Othello welcome you to work in Our community dedicated to maintaining a quality environment.

City of Othello's staff will work with you to create first class additions to our city. As staff, we believe being proactive and that the most productive way to help you through this process is to meet with you prior to the development of plans and details.

This document, in conjunction with the Othello Municipal Code (OMC), will provide you with our standards. These standards are intended to apply to all projects in the City of Othello. These specifications are developed for public works construction within the City of Othello and include construction of improvements that will be owned and/or maintained by the City of Othello. These improvements may be located on City owned property, public right-of-way, public right-of-way easements, or any other type of easement dedicated to the City of Othello. We feel that many of your questions will be answered here.

We attempt to achieve maximum uniformity of planning, engineering, and construction practices within the City of Othello. These are minimum standards and are intended to assist, but not to substitute for competent work by engineering and design professionals. Special conditions or environmental constraints may require a more stringent design than would normally be required under these standards. A proposed design, which deviates from these Public Works Standards, will follow the deviation process to be considered on the basis that the proposed design will produce a comparable or superior result and, in every way, adequate for the user, the City, and the public.

This document may contain minor errors, discrepancies or omissions, and is a living document. Therefore, can be updated on an annual basis or as needed.

Terry Clements
Public Works Director
City of Othello
111 North Broadway Avenue
Othello, WA 99344
Phone (509) 488-6997
Fax (509) 488-3701
tclements@othellowa.gov

CONSTRUCTION REQUIREMENTS

The following items are required for construction within any right-of-way or municipal easement; connection to an existing City utility; or extension of private water and sewer mains and appurtenances on private property.

The City Engineer shall make available the WSDOT Standard Specifications for Road, Bridge, and Municipal Construction”, “Public Works Design Standards”, and “American Public Works Association (A.P.W.A.) Standards” to the Public. Also, comprehensive plans for the orderly development of the City of Othello’s utilities and streets, will be available to guide in preparation of preliminary plats and specifications.

The Contractor shall perform all work in accordance with OSHA and WISHA safety regulations. The Contractor shall construct all work in conformance with the current WSDOT Standard Specifications for Road, Bridge and Municipal Construction as amended by the City of Othello Public Works Design Standards and Special Provisions approved by the Engineer. The Contractor shall be responsible to check on any revised Public Works Design Standards that may be in effect at the time of construction.

No person, firm or corporation shall commence work on the construction, alteration or repair of any facility located either in the public right-of-way or a public easement without the necessary permit(s) first having been obtained from the City.

In requesting a permit to work in public right-of-way, the Developer/utility agrees to indemnify and hold harmless the City from all claims for damages by third parties, including costs and reasonable attorney's fees in the defense of claims for damages, arising from performance of the Developer's express or implied obligations under this Agreement. The Developer waives any right of contribution against the City. For the purpose of applying RCW 4.24.115 to this Agreement, the Developer and the City agree that the term “damages” applies only to the finding in a judicial proceeding and is exclusive of third-party claims for damages preliminary thereto.

The Contractor shall have a City of Othello Street and Utility Construction Bond in the amount of 150 percent of construction costs within the City’s right-of-way.

All contractors and subcontractors shall have a current Washington State Contractors License and a City Business License on file with the City.

Any financial involvement from the City shall be determined and agreed upon prior to the issuance of the permit.

Right-of-Way permits for minor projects shall be issued through the Public Works Department and all other projects will be reviewed through the Engineering Department. Examples of minor projects are as follows:

- Installation or replacement of sidewalk or driveway
- Installation of side services
- Installation of monuments and cases

RIGHT-OF-WAY PERMITS – MINOR PROJECTS

For minor projects the right-of-way permit fee is \$40.00 and it covers the City's costs to issue the permit, an initial site visit, and a final inspection. With the application the Contractor shall provide a cost estimate of the work to be completed in the right-of-way for review by the Public Works Director. The Public Works Director will base approval of the cost of the project on a reasonable estimate of what the project would cost the City of Othello. Any additional inspections, City supplied equipment or materials, and overtime required by the project will be charged to the Contractor using the formula based on the Associated General Contractors of America.

Any party requesting such permit shall file written application therefore with the City at least 20 working days before construction is proposed to start. Such application shall include:

- (1) The name and address and phone number of the applicant (name and address of property owner if different than applicant) and applicant's contractor.
- (2) The name and address of the owner of the property abutting the street where the work is proposed;
- (3) The street location of the proposed work, giving the street address or legal description of the property involved;
- (4) A detailed plan showing the dimensions of the abutting properties and the dimensions and location of all existing and/or proposed facilities and other pertinent features to understand the proposed work;
- (5) The plan shall also show the location of buildings, loading platforms, roof overhangs (if significant) or off-street parking facilities in the vicinity of the new construction. No plan shall be approved, nor a permit issued where it appears that the proposed work, or any part thereof, conflicts with the provisions of this document or any other ordinance of the City of Othello, nor shall issuance of a permit be construed as a waiver of any ordinance requirements concerning the plan. Any permit issued in error shall be null and void.
- (6) Any other information requested by the City which is necessary to properly enforce the provisions of this ordinance.
- (7) Schedule of any closing or rerouting of the public around the construction.

RIGHT-OF-WAY PERMITS – MAJOR PROJECTS

For major projects, a pre-design meeting with the City Engineering Department is encouraged. These projects consist of any work to extend the City's existing street, water, sewer, storm, or irrigation systems. Major project will consist of review, construction, and maintenance phases.

REVIEW PHASE

The review phase shall begin with the submittal of engineer stamped plans and payment for Plan Review Fees.

Plan Review Fees shall be \$250 per sheet and be received by the City prior to the start of the review process. The fees will cover review of the initial set of plans and one revision. If additional reviews are required, staff time will be charged to the Developer. Plans for non-city public utilities, like gas, power, and communications, will also go through this process, but will not be billed if they have a Franchise with the City.

A complete submittal shall consist of the following:

- (1) If the improvements are related to platting, the Developer shall have the preliminary plat approved in accordance with Title 16 of the OMC.
- (2) The Developer shall submit detailed construction plans of the proposed improvements/utility.
- (3) The Developer shall submit the plat drawings conforming to the conditions of preliminary plat approval showing all rights-of-way and easements to be dedicated to the City.
- (4) Written approval from all regulatory agencies including SEPA mitigation approval shall be submitted.
- (5) Any requests for City participation.

Signature blanks are required on each Construction Plan sheet.

Construction plans with on-site fire hydrants shall also be reviewed and approved by the Adams County Fire District 5.

The developer shall provide circuitry for all required street lighting in conjunction with AVISTA or Big Bend Electric Cooperative (BBEC). Street lighting and circuitry plans shall be as approved AVISTA or BBEC for inclusion into the Construction Plans when required.

Plans for new public utilities shall be submitted with Construction Plans and shall be approved by the respective utility. The Contractor shall install all new telephone, electric, cablevision and other public utilities underground.

Once all review comments have been addressed and plans are ready to be signed by the City, provide two full-size, paper sets of the drawings to the City Engineer for signatures. One set will be returned to the Developer.

CONSTRUCTION PHASE

Prior to construction, the Construction Plans and specifications for municipal improvements, and private water mains and sewer mains shall be approved and signed by the City Engineer and the City Administrator.

No person, firm or corporation shall commence work on the construction, alteration or repair of any facility located either in the public right-of-way or a public easement without the following:

A pre-construction conference may be required between the Contractor, City staff, and all affected utilities. The City has conference rooms available for this meeting.

Provide cost estimates for all the work included in the entire project and for the work to be completed within City right-of-way.

Inspection Fees will be 2.5% of the construction costs for the entire project.

All Insurance and Bonding is in place as required by the City.

The Contractor shall provide a traffic control plan for work within the City's right-of-way reflecting the requirements set forth in the MUTCD.

The Contractor shall provide submittals to the Engineer for approval on all non-standard materials.

Inspector hours are between the hours of 8:00 a.m. and 3:30 p.m. Work that requires inspection outside of the regular hours shall be coordinated with the Engineer. Inspector overtime hours shall be in accordance with Section 1-08.0(2).

All required construction staking shall be performed under the direction of a Professional Land Surveyor.

The City Engineer may deviate, waive, or add to the preceding items based on the extent and nature of the proposed construction.

Once work is completed per the approved plans, all punch list items are completed, and the maintenance bond is provided by the Developer, the improvements shall be accepted by City Council and the one-year maintenance period shall begin.

MAINTENANCE PHASE

The maintenance phase shall begin with the acceptance of the improvements by City Council and shall extend for one year after that date.

A 1-year maintenance bond is required in the amount of:

- 100 percent of the project's costs of municipal improvements for projects up to \$150,000.00
- A minimum of \$150,000 or 50 percent of the project's costs of municipal improvements for projects \$150,000.00 - \$500,000.00.
- A minimum of \$250,000 or 25 percent of the project's costs of municipal improvements for projects \$500,000.00 and up.

Prior to the end of the 1-year maintenance phase, the City shall complete a project walk through and provide the developer with a 1-year punch list. The maintenance period will be complete once the 1-year punch list items are completed to the City's satisfaction.

DEVIATION PROCEDURE

The WSDOT *Standard Specifications for Road, Bridge and Municipal Construction* as revised by the *Public Works Design Standards* may be deviated subject to the approval by the City Council or the City Engineer.

A request may be made to the City Engineer for a deviation of any requirement of the *Public Works Design Standards*. All requests shall be in writing and sent to the City Engineer at 500 East Main Street, Othello, Washington, 99344.

Upon receipt of a request or recommendation for a deviation to the *Public Works Design Standards* the City Council or the City Engineer shall consider the deviation request at or prior to its next regular meeting, provided that the request is submitted for review two weeks prior to the City Council meeting. The City Council shall approve, conditionally approve, or disapprove the deviation request in compliance with the following requirements.

1. Deviations shall not be approved that would be detrimental to the public health, safety, or welfare; or that would be injurious to real property.
2. A deviation approval may require such conditions as may serve the objectives of the requirement that is being deviated, insofar as is practicable.

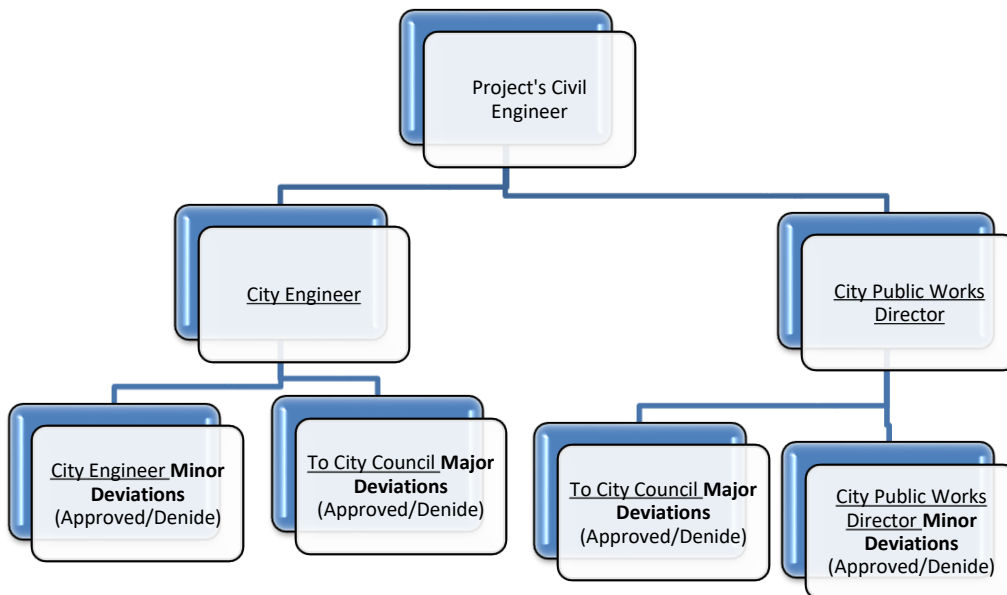

Attachment 1: Request for a Design Deviation

Project Name:

Date:

List the deviations from the City of Othello Design Standards you are proposing. For each deviation requested, explain the reasons why City Design Standards cannot be met, and describe how the proposed deviation will satisfy requirements for safety, function, fire protection, appearance and maintainability. Attach additional supporting information as needed.

Submitted by – (please print):

Company:

Signature:

FOR CITY USE ONLY	
<input type="checkbox"/>	Approved
<input type="checkbox"/>	Denied

DIVISION 1 GENERAL REQUIREMENTS

1-01 DEFINITIONS AND TERMS

1-01.2(2) ITEMS OF WORK AND UNITS OF MEASUREMENT

The section is supplemented with the following:

AWG	American Wire Gauge
CSTC	Crushed Surfacing Top Course
CSBC	Crushed Surfacing Base Course
D	Depth
DI	Ductile Iron
FIPT	Female Iron Pipe Thread
FL	Flanged
FT.	Feet
ID	Inside Diameter
IPT	Iron Pipe Thread
L	Length
Max.	Maximum
MH	Manhole
MIPT	Male Iron Pipe Thread
Min.	Minimum
MJ	Mechanical Joint
OC	On center
OD	Outside Diameter
PE	Polyethylene
PIP	Pressure Irrigation Pipe
R	radius
Rebar	Reinforcing Steel
ROW	Right-of-way
SF	Square Feet
SW	sidewalk
typ.	Typical
W	Width
x	By
X-brace	Cross-brace

1-01.3 DEFINITIONS

The section is revised by replacing the following definitions.

Contracting Agency

The Contracting Agency, as used in the Standard Specifications, is the City of Othello. The venue of all causes of action arising from the advertisement, award, execution, and performance of the contract shall be in Adams County Superior Court.

Contractor

Contractor is the individual, partnership, firm, corporation, or joint venture permitted by or contracting with the City to do prescribed work.

Department, Department of Transportation

All references in the Standard Specifications to the terms “Department” or “Department of Transportation”, shall be revised to read “City of Othello”.

Engineer

Engineer is the City Engineer or designated representative.

Special Provisions

Special Provisions are Construction Plans and specifications that are approved by the City Engineer and are provided for a specific project. Special Provisions revise the Public Works Design Standards and the Standard Specifications. In cases of discrepancy, the Special Provisions govern over the Public Works Design Standards and Standard Specifications.

State

All references in the Standard Specifications to the terms “State” shall be revised to read “City of Othello”.

The section is supplemented with the following:

Attorney

Attorney is the attorney who is duly authorized to act for the City in matters pertaining to law.

Block

The area of a City Street between two street intersections.

Building Sewer

Building sewers are sewer service lines that begin two feet from the edge of the building and ending at the Publicly Owned Treatment Works (POTW) sewer main. The building sewer includes the connection to the POTW sewer main. Building sewers are privately maintained. All building sewers require a Right-of-Way permit, a plumbing permit, or both, prior to construction, maintenance, or repair.

City

City is the City of Othello.

City Council

City Council is the duly elected or appointed Council of the City of Othello, Washington.

City Engineer

City Engineer is the City of Othello City Engineer.

City Street

City Street is any street within dedicated right-of-way, easement, or other public property including arterial streets, collector streets, neighborhood streets within the City limits.

The City Engineer shall classify all proposed City Streets and all City Streets that are annexed after the publication of this edition, as either an arterial street, collector street, or local street.

Arterial streets

Arterial streets are streets that carry the majority of traffic that enters and exits urban areas and that carry the majority of through traffic. Arterial streets have either fully controlled or partially controlled accesses. Arterial streets include interstate highways, state highways, and the following specific City Streets:

<u>Street</u>	<u>Portion</u>
Columbia Street	From Broadway East to 150' E. of 14 th Avenue
Broadway Avenue	From Hamlet Street South
Lee Street	Entire length
Main Street	State Route 17 to Broadway
7 th Avenue	From Main Street South to Columbia Street

Collector streets

A collector street is a low to moderate capacity road which serves to move traffic from local streets to arterial roads.

<u>Street</u>	<u>Portion</u>
Broadway Avenue	Hamlet Street to Lee Street
Cemetery Road	14 th to East End
Concrete Drive	Entire Length
Columbia Street	150' E. of 14 th Avenue to the East End
Cunningham Road	Broadway to West End
Curtis Road	Entire Length
Juniper Street	Broadway Avenue to 14 th Avenue
Lee Street	Olympia Street to Lee Street
Olympia Street	Broadway Avenue to 14 th Avenue
Scotney Street	Broadway Avenue to 14 th Avenue

4th Avenue
7th Avenue
10th Avenue
14th Avenue

Main Street to Scooteny Street
from Columbia Street North to Olympia Street
Main Street to Gemstone Street
Entire Length

Neighborhood streets

Neighborhood streets are all City Streets that are not classified as either an arterial street, or a collector street.

Commission

All references in the *Standard Specifications* to the term “Commission” shall be revised to read “City of Othello”.

Compacted Backfill

Compacted Backfill is any acceptable backfill material that has been compacted to 95 percent of the maximum density in accordance with Section 2-03.3(14) D.

Construction Plans

Construction plans are plans approved by the City Engineer. Construction plans may be required from a Professional Engineer. Construction plans may require a vicinity map, description and location of municipal improvements, location of right-of-way and easements, details for the work, a summary of quantities, structure notes, and other items required to show the Work being authorized by the City.

Developer

Developer is a person, firm, corporation, Contractor, subdivider, or other individual or agent of any person or party who is responsible for installing municipal improvements. Municipal improvements may include repairs or modifications to existing improvements, or new construction; whether they are proposed by the developer or required in accordance with City ordinance. The developer shall assume or cause to be assumed the definition and responsibilities of Contractor (Section 1-01.3).

Deviation

Deviation is a modification to any requirement of the *Public Works Design Standards* or *Othello Municipal Code* that has been approved by the City Council or City Engineer.

Drain Rock

Drain rock is the same as Gravel Backfill for Drains, as amended by Section 9-03.12(5).

Final Acceptance Date

Final acceptance date is the date that the City Council accepts the project.

Headquarters

All references in the *Standard Specifications* to the term “Headquarters” shall be revised to read “City”.

Main

Water mains are all potable water pipes that are 4 inches in diameter and larger, and all potable water pipes that serve more than a single service line.

Sewer mains are all sewer pipes that have an inside diameter larger than 6 inches, and all sewer pipes that service more than one property. Sewer mains include all new sewer pipes that terminate in a manhole.

Sewer mains and water mains may be municipal or private.

May

May is a permissive condition. Where the term “may” is used, it shall be at the discretion of the Engineer.

Pipe Bedding Zone

Pipe Bedding Zone is the zone around the pipe that is 6 inches from any portion of the pipe or its appurtenances.

Public utility

A privately or publicly owned and operated business whose services are so essential to the general public as to justify the granting of a franchise by the City.

Saw-cutting

Saw-cutting pavement is any method allowed by the Engineer to provide a clean, vertical edge/break without any fractures for asphalt/concrete removal. These methods may include pneumatic cutters, zippers, or wheel cutters.

Secretary

All references in the *Standard Specifications* to the term “Secretary” shall be revised to read “City of Othello”.

Secretary of Transportation

All references in the *Standard Specifications* to the term “Secretary of Transportation” shall be revised to read “City of Othello”.

Select Backfill

Same as bedding material acceptable by Section 7-09.3(9).

Shall

Shall is a mandatory condition. Where requirements are described with “shall”, the requirements are mandatory.

Should

Should is an advisory condition. Where the word “should” is used, it is considered to be advisable usage, recommended but not mandatory.

Standard Specifications

Standard Specifications are the WSDOT Standard Specifications for Road, Bridge and Municipal Construction. Standard Specifications are revised by the Public Works Design Standards and the Special Provisions.

State Materials Laboratory

All references to: “State Materials Laboratory” shall be revised to read “location designated by the City of Othello”.

State Treasurer

All references in the Standard Specifications to the term “State Treasurer” shall be revised to read “City of Othello”.

Traffic

Traffic consists of both vehicular and non-vehicular traffic, such as pedestrians, bicyclists, wheelchairs, and equestrians.

Undisturbed Ground

Undisturbed ground is any ground or soil that is continuous for 10 feet in any direction of a thrust block; and that has either never been disturbed or trenched through, or that has been compacted to 95 percent of maximum density.

Washington State Transportation Commission

All references in the Standard Specifications to the term “Washington State Transportation Commission” shall be revised to read “City of Othello”.

Water Service Line

Water service lines are potable water pipes that connect water services between the building and the water main. All water service lines shall be metered lines. Water service lines are privately maintained between the meter tile and the building, and for all water service lines that are connected to private water mains. Water service lines require a ROW permit, a plumbing permit, or both, prior to construction, maintenance, or repair.

1-02 BID PROCEDURES AND CONDITIONS

1-02.2 PLANS AND SPECIFICATIONS

The section is replaced with the following:

The Contractor shall obtain copies of the approved Construction Plans and have available on site.

1-04 SCOPE OF THE WORK

1-04.1 INTENT OF THE CONTRACT

The section is supplemented with the following:

The developer shall furnish all labor and materials necessary to provide Construction Plans, specifications, subdivision drawings, engineering, and other related items associated with a development project.

1-04.2 COORDINATION OF CONTRACT DOCUMENTS, PLANS, SPECIAL PROVISIONS, SPECIFICATIONS, AND ADDENDA

The section is revised by replacing items 1 through 7 as follows:

1. Addenda approved by the City Engineer,
2. Special Provisions approved by the City Engineer,
3. Construction Plans that are approved by the City Engineer,
4. Public Works Design Standards,
5. Public Works Design Standards Construction Details,
6. Standard Specifications,
7. Standard Plans

The following section (1-04.12) is added:

1-04.12 WASTE SITES

Waste sites shall be provided by the Contractor. Waste sites shall be operated in such a manner as to meet all laws, ordinances, and safety and health requirements of the State, County, and City. Waste sites shall not be permitted if operations or results of such operations create a nuisance problem, or result in damage to municipal, public, or private properties. Waste sites within the City of Othello may require a grading permit from the Building Department.

The Contractor shall provide the Engineer with copies of all excavation and grading permits that are required by Othello Municipal Code.

The following section (1-04.13) is added:

1-04.13 USE OF PRIVATE PROPERTY

The Contractor shall obtain permission from the property owner before using any private property adjoining the work. The Contractor shall obtain a written release from all damages that has been signed by the property owner; and the Contractor shall provide the written release to the Engineer prior to the City's acceptance of the project.

1-05 CONTROL OF WORK

1-05.3 WORKING DRAWINGS

The following section (1-05.3(1) is added:

1-05.31 DRAWINGS

The City of Othello Street Standard Drawings are hereby supplemented with the Washington State Department of Transportation/APWA Standard Specifications for Road, Bridge, and Municipal Construction, current edition. Both standard components apply to all public facilities construction within the City. In the event of conflicting details or specifications, precedence shall be in the following order:

1. City of Othello Street Standard Drawings
2. Washington State Department of Transportation/APWA Standard Specifications for Road, Bridge, and Municipal Construction, current edition
3. City-Approved Project Plans

Project plans shall have a horizontal scale 20 feet to the inch and a vertical scale of not more than 5 feet to the inch.

1-05.32 VERTICAL DATUM

The City of Othello has established the USBR elevation datum to be the official vertical datum to be used on all projects within the City of Othello and projects connecting to City of Othello systems.

All commercial/industrial projects in the area are required to have the following statement on the preliminary and final record drawings.

“VERTICAL DATUM.”

“The elevations shown on these plans are based on the elevation of the bench mark

monument located at the intersection of _____ Avenue and _____ Street and checked for accuracy by closing to the elevation monument located at _____ Avenue and _____ Street, according to the City of Othello official elevation bench mark list dated _____, the records of Othello, Washington.”

If the National Geodesic Vertical Datum of 1929 (NGVD-29) was used, it is converted to the USBR elevation by adding .89 feet to the NGVD-29 elevation. If North American Vertical Datum 1988 (NAVD-88) was used, it is converted to the USBR elevation by subtracting 2.8 feet from the NAVD.

The following official benchmarks are hereby established throughout the City.

DESCRIPTION	LOCATION	ELEVATION
USGS Brass Cap <i>N-547024.8927</i> <i>S-1971127.3946</i>	38' west of railroad track, 100' south of Main Street	1038.78
USBR Brass Cap	Steps of USBR building; 7th Avenue & Main Street	1104.56
Brass Cap	Canal structure, NE corner, 14th Avenue & Main Street	1118.08
USBR Brass Cap	Section corner monument; Broadway Avenue & Lee Street	1072.56
Brass Cap	1/4 corner monument; Broadway Avenue & future Olympia St.	1073.85
Steel Rod in Concrete	Section corner monument; Broadway Avenue & Main Street	1052.50
Brass Cap	1/4 corner monument; 7th Avenue & Lee Street	1118.68
Aluminum Cap	Center 1/4 corner monument; 7th Avenue and Olympia Street	1106.43
Brass Cap	Centerline monument; 7th Avenue & Scooteny Street	1071.28

Aluminum Cap	Section corner monument; 14th Avenue & Lee Street	1126.71
USBR Brass Cap	1/4 corner monument; 14th Avenue & Olympia Street	1115.84
Brass Cap	1/4 corner monument; 14th Avenue & just south of Ash Street	1097.27

1-05.4 CONFORMITY WITH AND DEVIATIONS FROM PLANS AND STAKES

The following section (1-05.4(1)) is added:

1-05.4(1) ROADWAY AND UTILITY SURVEYS

The Developer shall hire a professional land surveyor to set the following construction stakes and marks to establish lines, slopes, and grade; and the Contractor shall provide a copy of the survey notes to the Engineer.

1. Street construction control Offset stakes 3 feet behind sidewalk to top of curb elevation at 50-foot intervals.
2. Gravity sewer main construction control Offset stakes to pipe centerline and invert at changes in grade or alignment, and 50-foot intervals.
3. Water main and sanitary sewer force main construction control Offset stakes to pipe centerline and top of pipe at 100-foot intervals and at changes in alignment.
4. Structures control 2 offset stakes for location and elevation.
5. Finish grade for paving in curbed streets control requires (1) one row of blue tops at crown line at 50-foot intervals.
6. Finish grade for paving uncurbed streets control requires (3) three rows of blue tops (1 at crown and 1 at each edge of pavement.)
7. Subgrade for curbed streets control stakes are required (1) row of red tops at crown line at 50-foot intervals.
8. Subgrade for graveled, non-curbed streets control (1) one row of red tops along centerline at 100-foot intervals.

1-05.6 INSPECTION OF WORK AND MATERIALS

The section is supplemented with the following:

Inspection shall be performed by the Engineer or an engineering firm hired by the City.

Establishment of Development Review and Permit Fees shall be in accordance with “Construction Requirements” page 7 and shall be collected prior to issuance of a Right-of-Way Permit.

Permit fees do not include developer costs for required material testing. All costs for material testing required for the project shall be paid by the developer.

The Contractor shall request inspection a minimum of 48 hours prior to the Contractor’s scheduled need.

1-05.7 REMOVAL OF DEFECTIVE AND UNAUTHORIZED WORK

The section is supplemented with the following:

When the Engineer determines that public safety is affected, or that the situation may cause risk, loss, or damage, the Engineer may elect to accomplish repair by others and charge such costs to the developer.

Direct or indirect costs incurred by the City that are attributable to correcting and remedying defective or unauthorized work, or work the Contractor failed or refused to perform, shall be paid by the Contractor. Payment will be deducted by the Engineer from monies that are or will be due to the Contractor. On developer projects, where monies will not be due to the Contractor, additional permits and acceptance of work will be delayed until such monies are paid to the City. Such direct and indirect costs may include compensation for additional professional services required, compensation for repair and replacement of work of others destroyed or damaged by correction, and compensation for removal or replacement of the Contractor’s unauthorized work.

No adjustment in contract time, permit time, or compensation will be allowed because of the delay in the performance of the work attributable to the exercise of the City’s rights provided by this section.

The rights exercised under the provisions of this section shall not diminish the City’s right to pursue other solutions for additional remedies or damages with respect to the Contractor’s failure to perform the work as required.

1-05.10 GUARANTEES

The section is supplemented with the following:

If defective material or workmanship is discovered within 1-years after the date of Final Acceptance of the work, the Contractor shall return and either correct or replace the defective work as directed by the Engineer. If the weather, site conditions, or other factors delay the 1-year inspection or delay corrections from being made within 1 years after final acceptance, the Contractor's bond shall be extended for 1 additional year.

1-05.11 FINAL INSPECTION

The section is revised by replacing it with the following two sections (1-05.11(1) and 1-5.11(2)).

1-05.11(1) GENERAL

The Contractor shall complete all items required for a complete project before requesting the Engineer to perform a final inspection. For a complete project, all appurtenances shall be installed; all utilities shall be adjusted; all Portland Cement Concrete and HMA shall be placed; all backfilling shall be completed; all grouting shall be completed; all City Streets, curbs, and sidewalks shall be completed; and the entire project shall be debris free and washed, swept, or vacuumed as necessary to provide a project that is readily inspectable. The Engineer will provide a punch list to the Contractor after final inspection is completed by the City.

The Contractor shall complete all items on the punch list and provide a 1-year maintenance bond, per "Constructions Requirements" page 7, for municipal improvements before the project will be submitted to City Council for acceptance.

1-05.11(2) OPERATIONAL TESTING

It is the intent of the City for all projects to be complete and operable prior to acceptance. Therefore when the work involves the installation of machinery or other mechanical equipment; street lighting, electrical distribution, or signal systems; irrigation systems; buildings; or other similar work, it may be desirable for the Engineer to have the Contractor operate and test the work for a period of time after final inspection but prior to acceptance. Whenever items of work are listed in the Construction Plans and specifications for operational testing, the items shall be fully tested under operating conditions for the time period specified to ensure their acceptability prior to acceptance. During and following the test period, the Contractor shall correct any workmanship, materials, or equipment that are faulty or that are not in first-class, operating condition. Equipment, electrical controls, meters, and other devices and equipment to be tested during this period shall be tested under the observation of the Engineer. The Engineer will determine whether the items are suitable for the purpose that they were installed. The project will not be submitted for City Council acceptance until the Engineer determines that all testing and corrections are complete.

The costs for power, gas, labor, material, supplies, and everything else needed to successfully complete operational testing shall be paid by the Contractor.

Operational and test periods shall not affect a manufacturer's guaranties or warranties furnished with the project as required for acceptance.

1-05.12 FINAL ACCEPTANCE

The section is replaced with the following:

Acceptance by the City shall constitute final acceptance of the project. Final acceptance shall not constitute acceptance of any unauthorized or defective work or material. The City shall not be barred from requiring the Contractor to remove, replace, repair, or dispose of any unauthorized or defective work or from recovering damages for any such work or material.

Add the following two sections (1-05.16 and 1-05.17).

1-05.16 WATER AND POWER

The Contractor shall make necessary arrangements and shall bear the costs for power and water necessary for the performance of the work.

1-05.17 ORAL AGREEMENTS

No oral agreement or conversation with any officer, agent, or employee of the City shall affect or modify any of the terms or obligations contained in the right-of-way permit. Such oral agreement or conversation shall be considered as unofficial information and in no way binding upon the City, unless subsequently put in writing and signed by the City.

1-06 CONTROL OF MATERIAL

1-06.2 ACCEPTANCE OF MATERIALS

1-06.2(1) SAMPLES AND TESTS FOR ACCEPTANCE

The section is supplemented with the following:

The effective date of the AWWA Specifications is on the first day of the second month after publication. The AWWA Specifications and Revisions thus in effect at time of Construction Plan approval, or when the permit is issued if no Construction Plans are required, shall apply whenever referenced in these specifications. Copies of the AWWA

Specifications may be obtained from American Water Works Association, Inc., Customer Service, 6666 Quincy Avenue, Denver, Colorado 80235.

1-07 LEGAL RELATIONS AND RESPONSIBILITIES TO THE PUBLIC

1-07.1 LAWS TO BE OBSERVED

The section is supplemented with the following:

In cases of conflict between different safety regulations, the more stringent regulation shall apply.

The Washington State Department of Labor and Industries shall be the sole and paramount administrative agency responsible for the administration of the provisions of the Washington Industrial Safety and Health Act of 1973 (WISHA).

The Contractor shall maintain at the project site office, or other well-known place at the project site, all articles necessary for providing first aid to the injured. The Contractor shall establish, publish, and make known to all employees, procedures for ensuring immediate removal to a hospital, or doctor's care, persons, including employees, who may have been injured on the project site. Employees should not be permitted to work on the project site before the Contractor has established and made known procedures for removal of injured persons to a hospital or a doctor's care.

The Contractor shall have sole responsibility for the safety, efficiency, and adequacy of the Contractor's plant, appliances, and methods; and for any damage or injury resulting from their failure; or from improper maintenance, use, or operation. The Contractor shall be solely and completely responsible for the conditions of the project site, including safety for all persons and property in the performance of the work. This requirement shall apply continuously and shall not be limited to normal working hours. The required or implied duty of the Engineer to conduct construction review of the Contractor's performance shall not be intended to include review and adequacy of the Contractor's safety measures.

1-07.5 ENVIRONMENTAL REGULATIONS

1-07.5(3) STATE DEPARTMENT OF ECOLOGY

The section is supplemented with the following:

When a Construction Stormwater General Permit is required for a project development, the said permit shall be approved prior to construction of associated street and utility improvements.

The following section (1-07.5(5)) is added:

1-07.5(5) LIABILITY

The Contractor shall be liable for the payment of all fines and penalties resulting from failure to comply with the Federal, State, and local control regulations.

1-07.7 LOAD LIMITS

1-07.7(1) GENERAL

The section is revised by replacing paragraph 1 with the following:

While moving equipment or materials on any public street, road, or highway, the Contractor and its subcontractors, agents, or suppliers shall adhere to RCW 46.44 of the Motor Vehicle Laws of the State of Washington and local laws that either control traffic or limit loads. The Street and Utility Construction Permit neither exempts the Contractor, its subcontractors, agents, or suppliers from such laws, nor licenses overloads. At the Engineer's request, the Contractor shall furnish to the Engineer a listing of all haul vehicles to be used in the work. The list shall include vehicle owner license number, tare weight, and maximum legal load for vehicle and trailer.

1-07.13 CONTRACTOR'S RESPONSIBILITY FOR WORK

1-07.13(2) RELIEF OF RESPONSIBILITY FOR COMPLETED WORK

The section is replaced with the following:

The Contractor shall be responsible for maintaining and protecting all portions of the work until the project has been accepted by the City.

1-07.13(4) REPAIR OF DAMAGE

The section is replaced with the following:

The Contractor shall promptly repair all damage to either temporary or permanent work as ordered by the Engineer. When the Engineer determines that public safety is affected, or that the situation may cause risk, loss, or damage, the Engineer may elect to accomplish repair by others and charge such costs to the developer.

1-07.15 TEMPORARY WATER POLLUTION PREVENTION

1-07.15(1) SPILL PREVENTION, CONTROL, AND COUNTERMEASURES PLAN

The section is revised by replacing the first paragraph with the following:

A spill prevention, control, and countermeasures (SPCC) plan is required on all projects that disturb one or more acres of land through clearing, grading, excavating, or stockpiling of fill material. The area calculation will take into consideration the entire development project. When an SPCC plan is required, the Contractor shall provide the SPCC plan to the Engineer no later than the date of the preconstruction conference; or in the case of a project that does not require a preconstruction meeting, the SPCC plan shall be provided to the Engineer prior to permit approval.

1-07.16 PROTECTION AND RESTORATION OF PROPERTY

1-07.16(1) PRIVATE/PUBLIC PROPERTY

The section is supplemented with the following:

When trenching is required within right-of-way, the Contractor shall protect the existing curb, gutter, and sidewalk from damage; utilizing protective measures as approved by the Engineer. The Contractor shall demonstrate the method or procedure of protection, as directed by the Engineer, before proceeding with trenching. Any damage to existing improvements shall be repaired promptly at the Contractor's expense.

1-07.18 PUBLIC LIABILITY AND PROPERTY DAMAGE INSURANCE

The section [1-07.18] is replaced in its entirety with the following:

1-07.18(1) GENERAL REQUIREMENTS

The Contractor shall obtain and keep in force during the term of the Contract the following insurance with insurance companies or through sources approved by the State Insurance Commissioner.

The insurance company shall be licensed to do business in the State of Washington (or issued as a surplus line by a Washington Surplus lines broker). The City reserves the right to approve or disapprove the security of the insurance provided, the company, terms and coverage, and the Certificate of Insurance.

The policies of insurance for general and automobile policies shall be specifically endorsed to name the City of Othello Washington as additional insured.

In addition, Contractor's insurance shall be primary as respects to the City, and any other

insurance maintained by the City shall be excess and not contributing insurance with the Contractor's insurance.

Insurance shall provide coverage to the Contractor, all subcontractors, and the City. The coverage shall protect against claims for personal injuries and claims for property damages that may arise from any act or omission of the Contractor or the subcontractor, or by anyone directly or indirectly employed by either of them.

Contractor hereby assumes all risk of damage to its property, or injury to its officers, directors, agents, Contractors in or about the property from any cause, and hereby waives all claims against the City. The Contractor further waives, with respect to the City only, its immunity under RCW Title 51, Industrial Insurance.

The Contractor shall not begin work under the Contract until the required insurance has been obtained and approved by the City.

Failure on the part of the Contractor to maintain the insurance as required shall constitute a material breach of Contract upon which the City may, after giving five working days' notice to the Contractor to correct the breach, immediately terminate the Contract; or at the City's discretion, procure or renew such insurance and pay any and all premiums in connection therewith, with any sums so expended to be repaid to the City on demand, or at the sole discretion of the City, offset against funds due the Contractor from the City.

All costs for insurance shall be incidental to and included in the unit Contract prices of the Contract, and no additional payment will be made.

1-07.18(2) COVERAGE AND LIMITS

The insurance shall provide the minimum coverages and limits set forth below. Providing coverage in these stated limits shall not be construed to relieve the Contractor from liability in excess of such limits. The cost of all claim payments falling within the policy deductible shall be the responsibility of the Contractor.

- A. Commercial General Liability Insurance shall provide the following limits, or greater:

Bodily Injury and Property Damage

\$2,000,000	General Aggregate
\$2,000,000	Products & Completed Operations Aggregate
\$1,000,000	Each Occurrence

- B. Commercial Automobile Liability shall provide the following limit, or greater:

Bodily Injury and Property Damage

\$1,000,000 combined single limit

1-07.18(3) SUBCONTRACTORS

Contractor shall include all subcontractors as insureds under its policies or shall furnish separate evidence of insurance as stated above for each subcontractor. All coverage for subcontractors shall be subject to all the requirements stated herein and applicable to their profession.

1-07.18(4) EVIDENCE OF INSURANCE

When the Contractor delivers the executed Contract for the work to the City, the Contract shall be accompanied by a Certificate(s) of Insurance and endorsements for each policy of insurance meeting the requirements set forth above.

An ACORD certificate Form 25, showing the insuring company, policy effective dates, limits of liability, and the Schedule of Forms and Endorsements.

A copy of the endorsement naming the City of Othello Washington as Additional Insured(s), showing the policy number. The form shall be signed by an authorized representative of the insurance company.

The certificate(s) shall not contain the following or similar wording regarding cancellation notification to the City: "Failure to mail such notice shall impose no obligation or liability of any kind upon the company."

The description on the Certificate of Liability insurance form and the corresponding endorsement shall reference the project name and the contract number.

1-07.18(5) SELF-INSURANCE

If the Contractor is self-insured for any liability coverage, a letter from the Corporate Risk Manager, or appropriate Finance Officer, is acceptable; stipulating if actuarially funded and fund limits; and showing any excess declaration pages that are required to meet the Contract requirements. Further, the letter shall advise how Contractor would protect and defend the City as an Additional Insured in their Self-Insured layer and shall include claims-handling directions in the event of a claim.

1-07.23 PUBLIC CONVENIENCE AND SAFETY

1-07.23(1) CONSTRUCTION UNDER TRAFFIC

The section is revised by replacing item No. 3 and Item No. 5 in paragraph 2 with the following:

3. The Contractor shall maintain roadway striping as directed by the Engineer. The Contractor shall provide a schedule for striping, subject to approval by the Engineer.
5. The Contractor shall keep drainage structures clean and operable and shall install filters or provide other approved procedures to eliminate contaminated water that originates from construction activities from entering the City's stormwater system, including drywells.

The section is supplemented with the following:

Deficiencies caused by the Contractor's operations shall be repaired at the Contractor's expense.

The Contractor shall provide access to emergency traffic such as police, fire, and emergency units at all times. The Contractor shall notify the Public Works Director/City Engineer prior to closing any street and immediately upon reopening a closed street. Public Works Director/City Engineer will notify City Police, Adams County Fire District, Othello School District, and Post Office. The Contractor shall also coordinate all construction activities with the school district, post office, disposal firms, and other services that may be operating in the project area. The Contractor shall be liable for all damages that result from failure to provide reasonable notice, access, or coordination.

When construction operations are such that debris from the work is deposited on the streets, the Contractor shall remove all deposits and debris that have accumulated on the roadway surface at least once per day, and the roadway shall be cleaned at the end of each work day. If daily removal is insufficient to keep the City Streets clean, the Contractor shall perform removal operations on a more frequent basis. If the Engineer determines that a more frequent cleaning is impractical or if the Contractor fails to keep the City Streets free from deposits and debris resulting from the work, the Contractor shall provide facilities for and remove all clay and other deposits from the tires and between wheels before trucks and other equipment travel over City Streets. If the Contractor fails or refuses to clean the City Streets, trucks, and equipment in question, the Engineer may order the work suspended at the Contractor's risk until compliance with the Contractor's obligation is assured; or the Engineer may order the City Streets in question cleaned by others. Such costs incurred by the City in achieving compliance with these requirements, including cleaning of the City Streets, shall be paid by the Contractor prior to final acceptance of the project. The Contractor shall have no claim

for delay, extension of contract time, or additional cost should the Engineer choose to suspend the Contractor's work until compliance is achieved.

The following section (1-07.23(1)A) is added:

1-07.23(1)A EXISTING TRAFFIC CONTROL AND STREET NAME SIGNS

Existing traffic control and street name signs that interfere with construction shall be relocated or removed by the Contractor and temporarily stored in a safe place. "Stop", "Yield", "Speed Limit", and "One-Way" signs shall be removed or relocated only upon approval by the Engineer. Existing signs shall not be removed until the Contractor has provided temporary measures enough to safeguard and direct traffic after the existing signs have been removed. Except as otherwise provided in the contract documents, preservation and maintenance of traffic control and street name signs shall be the sole responsibility of the Contractor. All temporary signs shall be in compliance with Section 1-10.3(3) of these specifications.

The Contractor shall reset temporarily relocated or removed traffic and street name signs in their permanent location as work progresses and permits. The Contractor shall replace signs and other traffic control devices that are damaged or lost by the Contractor. However, the Engineer may allow the Contractor to repair a damaged sign in lieu of its replacement.

The Contractor shall install temporary pressure-sensitive pavement marking tape or delineators on the same day that the Engineer notifies the Contractor that existing paint lines have been obliterated by construction activities. The Contractor shall remove said temporary markers after the Engineer approves of permanent traffic channelization that has been installed by the Contractor.

The following section (1-07.23(1)B) is added:

1-07.23(1)B MAINTAINING ACCESS

The Contractor shall maintain access to residential, commercial, and industrial property adjacent to the project. Access to residential property shall not be blocked for more than 8 consecutive hours. Access to commercial and industrial property shall not be blocked for more than 4 consecutive hours. The Contractor shall provide alternate access routes if the work requires blocking City Streets or driveways longer than the hours specified herein. The proposed alternate routes shall be approved by the Engineer prior to their use and the alternate routes shall be the responsibility of the Contractor at no expense to the City.

The Contractor shall provide a notice, 24 hours in advance, to all property owners whose

parking may be restricted. The notice shall indicate where they may park and the name and phone number of the Engineer and Contractor.

1-07.23(2) CONSTRUCTION AND MAINTENANCE OF DETOURS

The section is revised by replacing paragraph 2 with the following:

The Contractor shall be responsible for maintenance, control, and safeguarding of traffic on all detours necessary for construction, including on-site and off-site detours, unless otherwise relieved of this responsibility by the Engineer.

The section is supplemented with the following:

All detours within the limits of the project, required or necessitated by the work, shall be the responsibility of the Contractor. This work includes side street crossings, freshly placed Portland Cement Concrete, utilization of one or more lanes of the construction area for maintenance of through traffic, and all other related traffic control. Traffic control plans for such detours shall be in accordance with the requirements of Section 1-10.

1-07.24 RIGHTS OF WAY

The section is replaced with the following:

Street right-of-way lines, limits of easements, limits of proposed right-of-way for a preliminary plat, and limits of construction permits should be shown on Construction Plans. The Contractor's construction activities shall be confined within these limits, unless arrangements for use of private property are made. Whenever any of the work is accomplished on or through property other than public right-of-way or property that is owned by the developer, the Contractor shall meet and fulfill all covenants and stipulations of any easement agreement that is provided to the City from the owner of the private property. Copies of the easement agreements will be available to the Contractor as soon as practical after they have been provided to the Engineer. The Contractor shall not proceed with any portion of the work beyond the developer's property in areas where right-of-way, easements, or rights of entry have not been provided to the City. The Contractor shall provide each property owner 48 hours' notice prior to entry. This includes entry onto easements and private property where private improvements may require adjustment.

The Contractor shall provide all additional land and access to the land that the Contractor requires for temporary construction facilities, storage of materials, and other Contractor needs. However, before using any private property, the Contractor shall provide the

Engineer with a written permission from the private property owner that allows the Contractor to use the private site; and prior to acceptance of the project by the City, the Contractor shall provide the Engineer with written release from the property owner that indicates that the private property owner is satisfied with the condition of the property after the Contractor has completed the project. All statements from private property owners shall include the signature of the property owner, parcel number, address, and date of signature.

The following section (1-07.28) is added:

1-07.28 CONTRACTOR’S RESPONSIBILITY FOR SAFETY

The Contractor is solely responsible for the safety of all workers at the work site, no matter by whom they may be employed. Such responsibility shall include compliance with all local, State, and Federal safety laws, rules, and regulations that apply to work performed by the Contractor or subcontractors for the project. The Contractor is not relieved of this responsibility by actions of the Engineer in the inspection of work in progress to ensure project compliance with Construction Plans. The Engineers that are assigned to perform inspections are not safety inspectors. The Contractor shall obtain an opinion or inspection from the appropriate regulatory agency if the Contractor is uncertain as to the application of any safety rule or regulation.

The Contractor shall be solely and completely responsible for conditions of the job site, including safety of all persons and property during performance of the work. This requirement shall apply continuously and shall not be limited to normal working hours.

The Contractor shall be aware of the work site’s present condition. The Contractor shall indemnify and hold the City harmless from any and all claims arising from the condition of the work site or on account of any claim of unsafe conditions maintained at the work site during the term of this project.

1-08 PROSECUTION AND PROGRESS

The following section (1-08.0) is added:

1-08.0 PRELIMINARY MATTERS

1-08.0(1) PRECONSTRUCTION CONFERENCE

Prior to construction, the Engineer may determine that a pre-construction conference is required. The Contractor shall provide 1-week advance notice to the Engineer to schedule the meeting. The City Hall conference room is available for the meeting. The Engineer will provide notification about the meeting to the City departments, public

utilities, surveyor, developer, and developer's engineer. The Contractor shall notify all subcontractors about the meeting.

- A. The following items will be discussed at the preconstruction conference.
 - 1. Permit requirements
 - 2. Utility service fees and charges
 - 3. Initial progress schedule and designated contacts
 - 4. Working relationship among the parties associated or affected by the work
 - 5. Procedures for notifications, approvals, and submittals
 - 6. Working hours for the project
 - 7. Inspection requirements and schedules
 - 8. Safety standards and traffic control
 - 9. Other project related items
 - 10. Locates called in prior to any excavation

- B. The Contractor shall prepare the following items and submit them at the preconstruction meeting, if applicable.
 - 1. Construction cost breakdown
 - 2. Preliminary schedule
 - 3. Submittals for all non-standard items for approval
 - 4. Material sources for approval

1-08.0(2) HOURS OF WORK

Except in the case of emergency, or as approved by the Engineer, the project working hours shall be between 7:00 a.m. and 10:00 p.m. of a working day. The Contractor shall provide a schedule of the hours to be worked and shall notify the Engineer of all changes to the schedule as work progresses. All City inspections required for the project shall be scheduled between the hours of 8:00 a.m. and 3:30 p.m. All work in existing City right-of-way or on existing municipal utilities shall be scheduled when City inspectors are available. Work that requires a City inspector before 8:00 a.m. or after 3:30 p.m. shall be subject to the availability of City inspector or other City personnel, and shall require the Contractor to pay the overtime rate per the current rates for all City personnel required for the project. All City inspector overtime hours required for the project will be invoiced to the Contractor and are due prior to acceptance of improvements.

The Contractor shall not perform work that requires City inspections on holidays, Saturdays, Sundays, or before 7:00 a.m. or after 6:00 p.m. on any day unless written authorization is provided by the Engineer.

Permission to work Saturdays, Sundays, holidays, or non-typical working hours Monday through Friday may be subject to conditions set forth by the City. These conditions may include the requirement for City personnel to work overtime.

1-09 MEASUREMENT AND PAYMENT

This section is deleted from the Public Works Design Standards on developer funded projects. On projects using City funds, the section shall remain in its entirety.

1-10 TEMPORARY TRAFFIC CONTROL

1-10.2 TRAFFIC CONTROL MANAGEMENT

1-10.2(3) CONFORMANCE TO ESTABLISHED STANDARDS

The section is supplemented with the following:

The Contractor may submit alternate proposals to those for traffic control and detours required by contract documents. Such alternate proposals shall safely and adequately maintain vehicular and pedestrian traffic and shall comply with the most recent version of the MUTCD. Proposals shall be submitted in writing to the Engineer five days in advance of their intended use. The acceptance of any proposal shall be entirely at the discretion of the Engineer. The Contractor shall be solely responsible for any and all liability associated with traffic control.

1-10.3 TRAFFIC CONTROL LABOR, PROCEDURES, AND DEVICES

1-10.3(3) TRAFFIC CONTROL DEVICES

1-10.3(3)A CONSTRUCTION SIGNS

The section is supplemented with the following:

The Contractor shall provide the traffic signing and traffic control in accordance with the approved Traffic Control Plan. The Contractor shall provide additional signs, barricades, cones, flaggers, and traffic control to ensure public's safety in accordance with the Contractor's plan of operation.

The Contractor shall erect all signs specified by the Traffic Control Plan for an area where work is scheduled to be performed, prior to commencing work on the said area of the project. Work on any area of the project shall not commence until all signs, flaggers, and other traffic control devices for said area are in place and approved by the Engineer.

The Contractor shall patrol the traffic control area and shall reset all disturbed signs and traffic control devices upon discovery or notification. All signs necessary for nighttime

traffic control shall be fully reflectorized. The Contractor shall make the necessary changes to any signs or traffic control devices that need to be repeatedly reset to ensure the problem does not continue.

Additionally, the Contractor shall have on the job a sufficient number of type II barricades and 28-inch orange plastic cones to provide for safe working conditions and to protect the traveling public.

For nighttime use, barricades shall be equipped with flashing lights in conformance with the MUTCD. Barricades and cones shall be bright in color and in good working order. Cones shall have a 6-inch-wide, reflectorized, white band placed 3 to 4 inches from the top. A second reflectorized, white band shall be placed at 2 inches below the upper band and shall be 4 inches wide. Broken, faulty, or nonstandard equipment shall be replaced upon discovery or notification.

The Contractor shall assume full responsibility for maintaining safe conditions on the job site at all times. The Contractor shall provide additional signs, barricades, cones, and other safety equipment as necessary to provide safe conditions and to conform with the MUTCD. The Engineer shall reserve the right to stop all work on the project until adequate traffic control is provided by the Contractor. All costs for traffic control shall be paid by the Contractor.

Where construction affects the traffic on existing City Streets, the Engineer may direct parking restrictions. Signs required for restricted parking shall be provided and installed by the Contractor as approved by the Engineer. The Contractor shall be responsible for providing and maintaining signs required for parking restrictions on and off the project if the parking restrictions are due to construction activities.

The Contractor shall furnish all flaggers and furnish and maintain all temporary traffic control signs and devices necessary to control traffic during construction operations. Traffic control signs and devices shall conform to the requirements set forth in the MUTCD.

DIVISION 2 EARTHWORK

2-01 CLEARING, GRUBBING, AND ROADSIDE CLEANUP

2-01.1 DESCRIPTION

The section is supplemented with the following:

The Contractor shall remove all topsoil and sand within the limits of street and utility construction to a depth of 18 inches below final grade. Topsoil or sand shall not be used for embankment or backfill.

2-01.2 DISPOSAL OF USABLE MATERIAL AND DEBRIS

The section is revised by replacing paragraph 2 with the following:

The Contractor shall dispose of all debris in accordance with Section 2-01.2(2), Disposal Method No. 2-Waste Site.

2-01.3 CONSTRUCTION REQUIREMENTS

2-01.3(3) VACANT

The entire section (2-01.3(3)) is replaced with the following:

2-01.3(3) TREE REMOVAL

Where trees have been removed within a landscape area by the Contractor, the remaining stumps shall be removed to 8 inches below the final ground surface elevation. All leaves, branches, wood chips, and other debris deposited by the tree and stump removal process shall be removed by the Contractor within 24 hours after the tree has been removed. All holes that have been created by the removal of a tree within a landscape area shall be filled with topsoil. The surface shall be sod, bark, rock, or other material which matches the existing landscape. Furthermore, all other landscaping or improvements which have been disturbed by the tree and stump removal process, or other activity of the Contractor, shall be restored to their original condition.

Where a tree is removed within an area where streets, sidewalks, curbs or other improvements will be installed, the contractor shall remove the tree in its entirety, and the hole shall be filled with material suitable for compaction required for the improvement.

2-02 REMOVAL OF STRUCTURES AND OBSTRUCTIONS

2-02.3 CONSTRUCTION REQUIREMENTS

The section is supplemented with the following:

The removal of street improvements shall be conducted in such a manner as not to injure municipal improvements or public utilities that are to remain in place. The Contractor shall be responsible for damage to municipal improvements and public utilities that is caused by construction activities.

The Contractor shall remove manholes, catch basins, and structures as shown on the Construction Plans, or where structures or installations of Portland Cement Concrete, brick, block, or other items interfere with the construction. All abandoned pipe openings shall be plugged watertight with non-shrink-type concrete or grout.

Where the structures are removed, the voids shall be backfilled with suitable material and compacted to 95 percent of maximum density.

Unless otherwise directed, all casting, pipe, and other material of recoverable value, shall be carefully salvaged and delivered to the City in good condition and in such order of salvage as the Engineer may direct. Items deemed of no value by the Engineer shall become the property of the Contractor and shall be removed from the site.

2-02.3(3) REMOVAL OF PAVEMENT, SIDEWALKS, CURBS, AND GUTTERS

The section is revised by deleting items 1 and 2.

The section is supplemented with the following:

Pavement, sidewalks, curbs, and gutters shall be removed by the Contractor as shown on the Construction Plans and as directed by the Engineer. Sidewalk aprons and private walks on street grading and paving projects shall be removed to the extent necessary to provide for construction of pavements and curbs. The Contractor shall remove any additional sidewalk required to provide proper connections and grades, as determined by the Engineer.

The Contractor shall dispose of all pavement and concrete off site.

The following section (2-02.3(4)) is added:

2-02.3(4) FENCES

The Contractor shall remove and replace fences as shown on the Construction Plans and

as directed by the Engineer.

2-03 ROADWAY EXCAVATION AND EMBANKMENT

2-03.1 DESCRIPTION

The section is supplemented with the following:

The work shall also include the relocation of existing signs and mailboxes, and the removal and salvaging of existing landscaping improvements, plants, and irrigation lines lying within the limits of excavation or embankment.

2-03.3(7) DISPOSAL OF SURPLUS MATERIAL

2-03.3(7)A GENERAL

The section is replaced with the following:

The Contractor shall obtain a waste site for the disposal of surplus material.

The following sections (2-03.3(20)) are added:

2-03.3(20) PROTECTION OF EXISTING IMPROVEMENTS

2-03.3(20)A GENERAL

Utilities of record shall be shown on the Construction Plans insofar as it is possible to do so. Failure of the Owner to show the existence of subsurface objects or installations on the Construction Plans shall not relieve the Contractor from the Contractor's responsibility to call for utility locates, to make independent checks on the ground, nor relieve the Contractor from all liability for damages resulting from the work.

The Contractor shall provide notification to agencies that have utilities in place and shall cooperate with these agencies in the protection and relocation of the various underground installations. These agencies may give assistance in the location of the various utilities, but this will not relieve the Contractor from responsibility for any damage incurred, except as provided by State law.

The Contractor shall protect and preserve existing improvements that will remain within the right-of-way.

Trenching or other excavation that undermines curbs, sidewalks, driveways, footings or any other structures shall be backfilled with controlled density fill. Trench with less than

24" width shall require controlled density fill. Excess material from this excavation shall be removed to an approved site in accordance with Section 2-01.2.

Controlled density fill shall meet the requirements as stated in Section 2-09.3(1) E.

2-03.3(20)B SEWERS AND APPURTENANCES

The Contractor shall place a 3/4"-inch-thick plywood shield over all manhole channels within the construction area. The Contractor shall cover the shield with a 6-foot by 6-foot by 20-mil plastic tarp. The Contractor shall remove the shield after all debris has been removed from the manhole, after the ring and cover has been adjusted to final grade, and within 24 hours after final adjustment. The Contractor shall remove all debris that falls into the channel and shall rod or flush all pipes that contain construction debris. The Contractor shall provide a trap at the downstream manhole for any flushing or rodding procedures that may be required.

2-03.3(20)C DAMAGED WATER MAINS AND APPURTENANCES

The Contractor shall repair or replace any water valves, hydrants, valve boxes, and other appurtenances that have been damaged during construction.

2-03.3(20)D PRIVATE UTILITIES

Utilities within the City right-of-way, other than those owned and operated by the City, are in the right-of-way pursuant to franchises or to rights claimed under the laws of the U.S.A. or the State of Washington. The respective utility agencies are responsible for all modifications and relocations of their facilities, as directed by the City. The Contractor shall coordinate all work with the work of agencies that are affected by the construction work. The Contractor shall protect all public and private utilities from damage.

The Contractor shall be liable for all damages to public or private utilities resulting from the Contractor's operations, and the Contractor shall hold the City harmless from all damages resulting from the Contractor's operations.

2-03.3(20)E EXISTING IMPROVEMENTS

The Contractor shall remove and salvage all landscaping improvements, plants, and irrigation lines lying within the limits of excavation or embankment to the property Owner, as directed by the Engineer.

The Contractor shall carefully cut and cap remaining irrigation lines within the right-of-way and within 2 feet behind back of sidewalk.

The Contractor shall relocate existing mailboxes as required to provide continual mail service to all residents.

2-06 SUBGRADE PREPARATION

2-06.3 CONSTRUCTION REQUIREMENTS

2-06.3(1) SUBGRADE FOR SURFACING

The section is supplemented with the following:

9. All underground work contemplated in the area of the subgrade shall be completed and properly compacted before final subgrade is prepared for approval.

The following section (2-06.3(3)) is added:

2-06.3(3) GRADE TOLERANCE

Grade tolerance for surfaces to receive crushed surfacing or ballast shall be +0.02 feet. The Contractor may leave areas of the surface lower than the grade established by Construction Plans or as approved by the Engineer; however, these low areas shall be filled with crushed surfacing top course.

2-07 WATERING

2-07.3 CONSTRUCTION REQUIREMENTS

The section is supplemented with the following:

The Contractor shall apply water for dust control as directed by the Engineer.

The following section (2-07.3(1)) is added:

2-07.3(1) CITY WATER SOURCE

The Contractor shall secure permission from and comply with all requirements of the City before obtaining water from a City water source. The Contractor shall measure all water obtained from a City water source with a hydrant meter that has been obtained or authorized by Public Works at 111 North Broadway Avenue. The Contractor shall pay the hydrant meter rental rates and water charges. Current water meter rental rates and water charges may be obtained by contacting Public Works. The Contractor shall protect the City's hydrant meter and associated apparatus from damage, loss, or theft

until all items are returned to the possession of Public Works.

The Contractor shall furnish all connectors, wrenches, valves and small tools that may be necessary to meet the requirements of the City. The Contractor shall use hydrant wrenches to open and close hydrants.

When using the hydrant, the Contractor shall make certain that the hydrant valve is completely open or shut. An authorized auxiliary valve shall be provided by the Contractor on the outlet line for control purposes. Fire hydrant valves shall be closed slowly to prevent surging of the system.

When use of the hydrant is complete, the Contractor shall notify Public Works so that the hydrant may be inspected for possible damage. Any damage resulting from the use of the hydrant by the Contractor, including theft of City equipment, shall be repaired or replaced by the City, and the cost thereof shall be billed to the Contractor.

2-08 VACANT

The entire section (2-08) is replaced with the following:

2-08 EXPOSE EXISTING UTILITIES
2-08.1 DESCRIPTION

Where required on the Construction Plans, the Contractor shall excavate and expose existing utility crossings 24 hours prior to laying pipe. The Contractor shall leave the excavation open enough time to allow the Engineer to verify the location and elevation of the utility. Once the utility has been verified, the Contractor shall backfill and compact the excavation as required by these Specifications.

2-09 STRUCTURE EXCAVATION

2-09.3 CONSTRUCTION REQUIREMENTS

2-09.3(4) CONSTRUCTION REQUIREMENTS, STRUCTURE EXCAVATION, CLASS "B"

The section is revised by deleting paragraphs 4 and 5.

The section is revised by replacing paragraph 3 with the following:

The Contractor shall provide excavation and trench safety systems that meet the requirements of the Washington Industrial Safety and Health Act, RCW Chapter 49.17, and WAC 296-155 if workers enter any trench or other excavation that is 4 feet or more

in depth. Excavation and trench safety systems may include shoring, extra trench excavation, or other methods acceptable to the Department of Labor and Industries. The Contractor, alone, shall be responsible for worker safety, and the City assumes no responsibility.

The section is supplemented with the following:

The Engineer may approve a trench to remain open overnight in low-volume traffic areas. The Contractor shall submit a physical barrier protection plan for approval by the Engineer. The physical barrier protection plan shall include obstructions large enough to discourage traffic from entering the excavation and high strength polymer barrier fencing. The Contractor assumes all responsibility for open trenches and safety-protection measures.

2-11 TRIMMING AND CLEANUP

2-11.1 DESCRIPTION

The section is replaced with the following:

This work consists of neatly finishing construction areas to the lines, grades, and cross sections shown on the Construction Plans and as directed by the Engineer. The work shall include trimming and cleaning the entire roadway including planting areas, sidewalks, shoulders, driveways, alleys, side street approaches, slopes, ditches, and utility trenches.

2-11.3 CONSTRUCTION REQUIREMENTS

The section is replaced with the following:

The surface area of the project area shall be uniformly sloped after the Contractor has completed cleaning and dressing the project. Where the existing grade is below the top-of-sidewalk, top-of-curb, or both, the Contractor shall fill and dress the area to the top-of-sidewalk and top-of-curb regardless of limits shown on the Construction Plans. The Contractor shall place fill material high enough to allow for final settlement. The Contractor shall remove all rocks in excess of 2 inches in diameter from the surface for the entire construction area. All windrows of earth shall be removed entirely.

All surfaces and drainage facilities shall be clean. The Contractor shall dispose of all trash, construction stakes, debris, and other waste material. The Contractor shall remove and dispose of broken brush and trees, and construction debris beyond the limits of the project that are caused by construction.

The Contractor shall flush the street at the conclusion of the work. Flusher shall be of a pressure type. The Contractor shall furnish the water required. Sidewalks shall be hand broomed. Stormwater inlet protection shall remain in place until the project is trimmed and cleaned, flushed, and ready for final inspection.

DIVISION 4 BASES

4-04 BALLAST AND CRUSHED SURFACING

4-04.3 CONSTRUCTION REQUIREMENTS

4-04.3(2) SUBGRADE

The section is supplemented with the following:

The Contractor shall give the Engineer 24 hours' notice when construction of the subgrade has been completed. The Contractor shall not place crushed surfacing or ballast until the subgrade has been approved by the Engineer. Areas not conforming with the tolerances shall be corrected by the Contractor and approved by the Engineer prior to proceeding with the work. The Contractor may fill low areas with crushed surfacing or ballast at the Contractor's expense.

4-04.3(5) SHAPING AND COMPACTION

The section is supplemented with the following:

Grade tolerance for the surface to receive HMA shall be plus 0.02 feet or minus 0.04 feet. The Contractor shall give the Engineer 24 hours' notice when construction of crushed surfacing top course has been completed. The Contractor shall not place any asphalt tack until the finished grade has been measured and approved by the Engineer. Any areas not conforming to the above tolerance shall be corrected by the Contractor and re-measured and approved by the Engineer prior to proceeding with the work.

DIVISION 5 SURFACE TREATMENTS AND PAVEMENTS

5-04 HOT MIX ASPHALT

The entire Section 5-04 is replaced with the following:

5-04.1 DESCRIPTION

The last sentence of the first paragraph is revised to read:

The manufacture of HMA may include additives or processes that reduce the optimum mixing temperature (Warm Mix Asphalt) or serve as a compaction aid in accordance with the Specifications.

5-04.2 MATERIALS

The following sections (5-06) are added:

5-06 HMA PATCHING

5-06.1 DESCRIPTION

The work includes removal of concrete or pavement, placement of CSTC, placement of CSBC, application of tack coat, and placement of HMA.

5-06.2 MATERIALS

Materials shall meet the requirements of the following sections:

HMA	5-04
Crushed Surfacing Base Course.....	9-03.9(3)
Crushed Surfacing Top Course.....	9-03.9(3)

5-06.3 CONSTRUCTION REQUIREMENTS

5-06.3(1) GENERAL

The Contractor shall schedule all pavement patching to accommodate the demands of traffic.

For safety reasons, the Contractor shall patch all areas within traveled lanes on Arterial streets and Collector streets on the same day that pavement has been removed. An exception is that if the work will continue the next day, as authorized by the Engineer, the pavement that has been removed and not patched shall be covered by the Contractor with steel plates that can support the traffic.

The Contractor shall patch all areas within Neighborhood streets, and in non-traveled lanes for arterial and collector streets, where pavement has been removed, within 10 calendar days of the removal of original pavement.

Where pavement is removed and not patched, the Contractor shall provide a temporary

surface for traffic as authorized by the Engineer, which temporary surface shall be maintained by the Contractor until the patch is placed.

Saw-cutting shall be performed as shown on the Construction Plans or as directed by the Engineer.

The Contractor shall provide mechanical compaction for each lift of HMA by means of a roller, plate whacker, jumping jack, or hand tamper. However, the Contractor shall compact all patches that exceed 4-feet in width with a roller.

The Contractor shall expand the perimeter of the HMA patch as necessary to provide an even grade adjacent to the patch that doesn't have humps or dips, as directed by the Engineer. The Contractor shall widen all HMA patches to allow room for the compaction equipment that is being used. Additionally, the Contractor shall widen all patches that are adjacent to the curb to provide for a patch with a maximum cross slope of 6 percent towards the curb.

The Contractor shall apply a tack coat of asphalt to all existing surfaces of HMA, curbs, gutters, and appurtenances that will be covered by HMA. The tack coat shall cover the entire surface.

5-06.3(2) GRADE TOLERANCE

All HMA patches shall be at least (3") three-inches thick. Additionally, HMA patches shall match the depth of adjacent pavement if the adjacent pavement is between (3") three-inches thick and (6") six-inches thick. And, HMA patches shall be (6") six-inches thick if the adjacent pavement is (6") six-inches or thicker. However, the Engineer may allow a transition from thicker HMA depths to the required design depth for large patches.

Grade tolerance for the surface to receive HMA shall be in accordance with Section 4-04.3(5). The Contractor shall not place any HMA until the base has been authorized by the Engineer. The Contractor shall correct any areas that do not conform to the above tolerance, and the areas shall be authorized by the Engineer prior to proceeding with the work.

5-06.3(3) SPREADING AND FINISHING

The Contractor shall apply HMA in two lifts, with the depth of each compacted lift being not more than (2") two-inches. Additional lifts in (2") two-inch increments may be required. HMA shall be compacted in accordance with Section 5-04.3(10).

For HMA patches that are over 8-feet wide, and which patches are longer in the direction

of the centerline of the road, the Contractor shall use a paving machine or Layton box, unless otherwise authorized by the Engineer.

5-06.3(4) TRAFFIC CONTROL

Proper signs, barricades, lights, and other warning devices shall be maintained 24 hours a day until the patch is completed and ready for traffic.

5-06.3(5) TEMPORARY PATCHES

The Contractor shall place temporary patches within (10) ten calendar days if permanent patches cannot be constructed within (10) ten calendar days following excavation. Temporary patches consist of cold plant mix asphalt or Portland Cement Concrete. For cold plant mix patches, the Contractor shall provide proof of availability of cold plant mix prior to cutting the pavement.

Physical completion shall not be declared until the Contractor has replaced all temporary patches with permanent patches.

5-06.3(5)A TEMPORARY PATCHES-COLD PLANT MIX ASPHALT

1. Temporary cold mix patches shall be (2") two inches thick.
2. Temporary patches shall match existing grade.
3. The Contractor shall replace temporary patches with permanent patches prior to May 15th.
4. The Contractor may be required to expand temporary patches 12 inches around the perimeter of a temporary patch prior to placement of a permanent patch. The Contractor shall sawcut the additional pavement required for expanding the patch.

5-06.3(5)B TEMPORARY PATCHES-PORTLAND CEMENT CONCRETE

1. Portland Cement Concrete for temporary patches shall be Class 3000.
2. Temporary Portland Cement Concrete patches shall be (6") six inches in depth.
3. Temporary Portland Cement Concrete patches shall match existing grade.
4. The Contractor shall place steel plates over the Portland Cement Concrete patch area and shall restore traffic within (2) two hours after placing Portland Cement Concrete. The Contractor shall remove the steel plates after the Portland Cement Concrete has set up for (7) seven calendar days.
5. The Contractor shall replace temporary Portland Cement Concrete patches with HMA patches prior to May 15th.
6. The Contractor may be required to expand boundary of temporary patches, as necessary, around the perimeter of a temporary patch area prior to placement of a permanent HMA patch. The Contractor shall sawcut the additional pavement

required for expanding the HMA patch in order to removed rolled and damaged edges.

5-06.3(6) EXISTING PORTLAND CEMENT CONCRETE PATCHES

The Contractor shall remove and replace existing Portland Cement Concrete patches with HMA patches prior to overlay. All new HMA patches shall be in accordance with this section.

The following sections (5-07) are added:

5-07 ADJUSTMENT OF MANHOLES, CATCH BASINS, MONUMENT CASES, VALVE BOXES, AND CLEAN OUTS TO GRADE

5-07.1 DESCRIPTION

This work shall consist of adjusting manholes, monument cases, water valve boxes, and clean outs to grade.

5-07.2 MATERIALS

Materials shall meet requirements of the following sections:

Ballast and Crushed Surfacing Top Course	4-04
HMA	5-04
Portland Cement Concrete	6-02

Commercial Class Portland Cement Concrete can be used for adjusting utilities in accordance with Section 6-02.3(2) B.

HMA Cl. 3/8-inch PG 64-28 shall be used for utility adjustment patches; however, the Engineer may approve alternative mixes for HMA patches, provided that the Contractor can provide a finish HMA patch that is acceptable to the Engineer.

5-07.3 CONSTRUCTION REQUIREMENTS

5-07.3(1) PAVED SURFACES

The Contractor shall provide (4") four to (12") twelve-inches of adjustment rings between the top of cone or flattop section of a manhole and the bottom side of the manhole frame. Final elevation of the frame and cover shall be (1/4") one quarter inch below finish street grade.

The Contractor shall remove frames and adjustment rings from manholes and similar

structures so that the structure is (8") eight inches below subgrade whenever the structure is being rehabilitated or adjusted in conjunction with street paving or patching projects. The Contractor shall cover the lowered structures with a temporary metal cover. The Contractor shall reference each structure so that they may be easily found upon completion of the street work.

The Contractor shall adjust manholes, valve boxes, monuments, and other structures in the roadway after the pavement is completed. The Contractor shall locate the center of each structure from references that were previously established by the Contractor.

The Contractor shall cut and remove pavement in a neat circle or square. The diameter of the circle or side of the square shall be equal to the outside diameter of the frame plus (2') two feet to allow for compaction. The Contractor shall remove the crushed rock and base material around the appurtenance to the depth of required Portland Cement Concrete as shown on the respective detail. Wedges used for adjusting shall be non-organic. A maximum of (3) three wedges shall be used for any adjustment. No wedges shall protrude inside of the frame, and all loose wedges shall be removed prior to pouring Portland Cement Concrete. The Contractor shall compact the excavation area and place Portland Cement Concrete to within (2") two to (12") twelve inches of the top of the structure.

The Contractor shall complete the adjustment on the following day by applying a tack coat of asphalt to the Portland Cement Concrete, edges of the pavement, and the outer edge of the casting; and by placing and compacting HMA with hand tampers, plate whackers, or rollers. The final elevation of the HMA patch shall match the existing paved surface.

The Contractor shall apply non-shrink-type concrete or grout flush with the inside of the frame and adjustment rings upon completion of the final HMA patch. The Contractor shall remove excess concrete and grout within the structure at the completion of the adjustment.

5-07.3(2) UNPAVED SURFACES

The Contractor shall remove frames and adjustment rings from manholes so that the structure is (6") six inches below subgrade whenever the structure is being rehabilitated or adjusted in conjunction with street paving or patching projects. The Contractor shall cover the lowered structures with a temporary metal cover. The Contractor shall reference each structure so that it may be easily found upon completion of the street work.

The Contractor shall install Portland Cement Concrete pads around all manholes, valve boxes, monuments, and other structures that are not within paved surfaces. Final

elevation of the pad in graded roadways shall be at final street grade; whereas the final elevation for frames and covers outside of roadways shall be at final grade of existing terrain. All pads in the roadway shall be sloped towards the direction of traffic.

The Contractor shall adjust manholes, valve boxes, monuments, and other structures in the roadway after the final grading is completed. The Contractor shall locate the center of each structure from references that were previously established by the Contractor. The Contractor shall excavate around the top of each structure in a neat square. The Contractor shall remove the material around the structure to a depth required for Portland Cement Concrete as shown on the respective detail and to provide for (6") six-inch depth for the placement of a Portland Cement Concrete pad. The Contractor shall adjust the top of the appurtenance to the required elevation of the top of the pad. Wedges used for adjusting shall be non-organic. A maximum of (3) three wedges shall be used for any adjustment. Wedges shall not protrude inside of the frame, and all loose wedges shall be removed prior to placing Portland Cement Concrete. The Contractor shall compact the excavation area and place Portland Cement Concrete to the top of the frame and cover.

The Contractor shall apply non-shrink-type concrete or grout flush with the inside of the frame and adjustment rings after the pads have been placed. The Contractor shall remove excess concrete and grout within the structure at the completion of the adjustment. The Contractor shall complete the adjustment by removing the forms and by backfilling adjacent to the pad as may be required.

DIVISION 6 STRUCTURES

- 6-02 CONCRETE STRUCTURES
- 6-02.3 CONSTRUCTION REQUIREMENTS
- 6-02.3(2) PROPORTIONING MATERIALS
- 6-02.3(2)B COMMERCIAL CONCRETE

The section is replaced with the following:

Commercial class concrete shall not be used on City projects except as allowed by the Engineer for unexposed utility frame adjustments.

- 6-02.3(4) READY-MIX CONCRETE
- 6-02.3(4)C CONSISTENCY

The section is replaced with the following:

The slump for all concrete shall be (4") four inches or less.

**DIVISION 7 DRAINAGE STRUCTURES, STORM SEWERS, SANITARY SEWERS,
WATER MAINS, AND CONDUITS**

7-01 DRAINS

7-01.2 MATERIALS

The section is revised by replacing paragraph 1 with the following:

Materials shall meet the requirements of the following sections:

Gravel backfill for Drains	9-03.12(4)
Perforated Polyvinyl Chloride (PVC) Underdrain Pipe	9-05.2(6)
Polyvinyl Chloride (PVC) Pipe	9-05.12
Construction Geosynthetic	9-33

7-04 STORM SEWERS

7-04.2 MATERIALS

The section is replaced with the following:

Materials shall meet the requirements of the following sections:

Solid Wall PVC Storm Sewer Pipe	9-05.12(1)
Ductile Iron Sewer Pipe	9-05.13

7-04.3 CONSTRUCTION REQUIREMENTS

The following section (7-04.3) is supplemented with the following:

The Contractor shall use ductile iron pipe whenever the depth of cover under a roadway is 18 to 36 inches. The Contractor shall lay all ductile iron pipe, valves, and fittings with a polyethylene encasement installed in accordance with AWWA C105. PVC pipe can be installed at depths of (24") twenty-four inches and greater under sidewalks, provided that no portion of the PVC pipe is installed within the street (defined at face of curb). All contiguous pipe between stormwater structures shall be of the same diameter and material.

No storm drainpipe shall be buried deeper than (20') twenty feet except that installation to a depth greater than (20') twenty feet can be approved to avoid the need for a pump system. Unless otherwise approved by the City, pipes shall not be located underneath sidewalks, driveways, walls, or landscaped areas except for where drainpipes cross perpendicular to these areas.

7-05 MANHOLES, INLETS, CATCH BASINS, AND DRYWELLS

7-05.1 DESCRIPTION

The section is supplemented with the following:

The developer shall provide completed Washington State Department of Ecology (DOE) Underground Injection Control (UIC) applications to the Engineer for registering all proposed drywells with DOE, along with a reduced set of Construction Plans (11-inch by 17-inch). The City will assign a unique identification number for the applications and submit the completed applications to DOE for approval. Drywells will not be permitted for installation, and Construction Plans will not be approved for construction, until the City receives notification from DOE that the drywells are "Rule Authorized".

7-05.2 MATERIALS

The section is supplemented with the following:

Construction Geosynthetic 9-33

Utility castings shall be as shown on the appropriate construction detail.

7-05.3 CONSTRUCTION REQUIREMENTS

The section is supplemented with the following:

Entry couplings shall be used for all PVC pipe penetrations, with the exception of penetrations in barrel section. Mortar shall be applied between the pipe or entry coupling and the structure, where the pipe penetrates the structure, from both the interior and exterior of the structure. The manhole lid and ladder rungs shall be located left or right above the main inflow pipe where the inflow pipe. However, on manholes with dual entries or drop connections, the ladders shall be placed as directed by the Engineer, so that the flow does not enter at the ladder.

The Contractor shall bring channels together smoothly with well-rounded junctions. Channel sides shall be carried up vertically to the crown elevation of the various pipes, and the concrete shelf between channels shall be smoothly finished and warped evenly

with slopes to drain.

The Contractor shall seal catch basins on the outside by placing Portland Cement Concrete from 1-inch below the top of the base section to 1.5-inch below the top of the frame. The Contractor shall seal the frame and adjustment rings inside the catch basin with a non-shrink-type concrete or grout.

The Contractor shall install new frames, grates, and covers as directed by the Engineer whenever existing frames are adjusted. Replacement frames, grates, and covers shall be provided by the City. The Contractor shall deliver salvageable frames, grates, and covers to the City Shop at 111 North Broadway Avenue if the Engineer determines that they are salvageable; otherwise they shall become the property of the Contractor.

The Contractor shall store construction fabric for drywells in a dry place off the ground. Rolls shall be placed straight in piles. The construction material shall not be exposed to sunlight for more than a total of 40 hours, either during storage or placement.

The surface to be covered by the fabric shall be graded uniformly so that it is free from protruding rocks or other objects. The fabric shall be placed loosely as a liner for the ditch to avoid placing the fabric in tension upon backfilling. The fabric shall be placed with overlaps of 1 foot minimum. The Contractor shall not operate equipment directly on the fabric.

The Contractor shall repair or replace any fabric that is punctured or disturbed during construction in accordance with Section 2-12.

The Contractor shall provide mechanical compaction for drain rock that is placed below the base of drywell base.

7-05.3(1) ADJUSTING MANHOLES AND CATCH BASINS TO GRADE

The section is supplemented with the following:

Manholes and catch basins shall be adjusted in accordance with Section 5-07.

7-05.3(2) ABANDON EXISTING MANHOLES

The section is revised by replacing the first sentence of the Section with the following:

Where it is required that an existing manhole be abandoned, the structure shall be broken down to a depth of at least (4') four feet below the revised finish grade, all connections shall be plugged with non-shrink-type concrete or grout, and the manhole shall be filled with select backfill and compacted to (95) ninety-five percent maximum density.

7-05.3(3) CONNECTIONS TO EXISTING MANHOLES

The section is supplemented with the following:

The Contractor shall carefully penetrate the wall of the manhole at the elevation shown on the Construction Plans. PVC pipe penetrations shall be made using an authorized pipe entry coupling.

The following section (7-05.3(5)) is added:

7-05.3(5) DRYWELL

The Contractor shall compact the base layer of drain rock prior to placing the drywell base.

Construction geotextile shall be placed between the drain rock and the existing soil.

7-08 GENERAL PIPE INSTALLATION REQUIREMENTS

7-08.2 MATERIALS

The section is replaced with the following:

Gravel Backfill for Foundations	9-03.12(1)
Gravel Backfill for Pipe Zone Bedding	9-03.12(3)
Gravel Backfill for Drains	9-03.12(4)

7-08.3 CONSTRUCTION REQUIREMENTS

The section is supplemented with the following:

The City shall require mains to be oversized to handle future flows consistent with planning documents. Oversizing of mains and extending utilities to the far property lines shall be the responsibility of the developer.

All water, sewer, and irrigation services shall be stamped in face of curb at time of installation.

The Contractor shall lay all ductile iron pipe, valves, and fittings with a polyethylene encasement installed in accordance with AWWA C105.

TELEVISION INSPECTION

Municipal storm sewers shall be inspected using a television camera if the length of pipe

between structures exceeds (50') fifty feet. The Contractor shall provide copies of the video inspections to the Engineer. Video inspections shall be on format that can be downloaded on the city's computers for viewing.

All video inspections shall include the following information on the video:

- a. The name of the project and the name of the Contractor.
- b. The name of the street and the cross street if applicable.
- c. The beginning and ending manhole numbers, drywells, or catch basins, as referenced to the approved construction plans.
- d. The direction that the camera is traveling (either upstream or downstream).
- e. The distance shall be shown on the video inspection always, from the beginning manhole, catch basin, or drywell, as referenced to 0.0 feet for the beginning structure.
- f. For each structure, the camera shall perform a full video inspection of the inside of the structure.
- g. All abnormal conditions shall be noted, including repairs, debris, fractures, bellies, and standing water. Where abnormalities are noted, the Contractor shall be on notice that the pipe may not be in acceptable condition until repairs are completed, and the main is re-televised.

The television inspection shall be completed after the subgrade is prepared, and the Contractor shall not perform paving operations until the Engineer has reviewed video inspection reports and determined that the storm sewer lines are in acceptable condition.

All costs to provide video inspections shall be borne by the contractor, and the City will not provide television inspection services on storm sewer lines that are not yet accepted by the City.

7-08.3(1) EXCAVATION AND PREPARATION OF TRENCH

7-08.3(1)C BEDDING THE PIPE

The section is supplemented with the following:

The Contractor shall install pipe zone bedding material as shown on the Trenching and Bedding Detail. Pipe bedding shall conform to Section 9-03.12(3) or Section 9-03.22 for pipes installed above groundwater and above seasonal groundwater zones. Pipe bedding shall conform to Section 9-03.12(4) for pipes installed in groundwater or in seasonal groundwater zones.

7-08.3(2) LAYING PIPE

7-08.3(2)A SURVEY LINE AND GRADE

The section is revised by replacing the first paragraph with the following:

Survey line and grade control hubs shall be set in accordance with Section 1-05.4(1).

7-08.3(2)G JOINTING OF DISSIMILAR PIPE

The section is replaced with the following:

Dissimilar pipe shall be jointed with a factory-fabricated adapter coupling as authorized by the Engineer.

7-08.3(3) BACKFILLING

The section is revised by replacing sentences 3 thru 6 of paragraph 4 with the following:

The Contractor shall place backfill above the pipe zone bedding in horizontal layers that are no greater than 18-inches thick with a maximum aggregate of (6”) twelve inches or less. The Contractor shall compact each layer to (95) ninety-five percent maximum density. Material that is excavated from the trench may be used for backfilling above the pipe zone, except that organic material, frozen lumps, wood, or pavement chunks, concrete, or other foreign material shall not be used.

The following section (7-08.3(5)) is added:

7-08.3(5) DETECTABLE MARKING TAPE

The Contractor shall install detectable marking tape above all culverts, stormwater pipes, water pipes, conduits, irrigation, and sanitary sewer pipes. The tape shall be placed (2) two feet above the top of the pipe for the entire length of the pipe. Marking tape shall be in accordance with Section 9-15.18.

7-09 WATER MAINS

7-09.2 MATERIALS

The section is revised by deleting the following materials:

Steel Pipe (6 inches and over)	9-30.1(4)A
Fittings for Steel Pipe (6 inches and over)	9-30.2(4)A
Steel Pipe (4 inches and under)	9-30.1(4)B
Fittings for Steel Pipe (4 inches and under)	9-30.2(4)B

7-09.3 CONSTRUCTION REQUIREMENTS

The section is supplemented with the following:

Hydrant assemblies shall be installed within (4') four feet of all new dead-end water mains before being placed in service. Blow-off assemblies may be authorized by the Engineer in lieu of hydrant assemblies for temporary dead-end water mains that are to be placed in service.

Cul-de-sacs with 8" water mains must have a flushing mechanism. 2" water service line serving multiple lots may be permitted with an approved engineered design.

7-09.3(5) GRADE AND ALIGNMENT

The section is revised by replacing sentence 1 of paragraph 3 with the following:

The depth of trenching for water mains shall provide (42) forty two inches of cover over the top of the pipe unless otherwise shown on the Construction Plans or authorized by the Engineer.

7-09.3(7) TRENCH EXCAVATION

The section is revised by replacing paragraph 3 with the following:

Trench excavation within right-of-way or municipal easements shall not be more than (150) one hundred fifty feet ahead of the pipe-laying operation. The Engineer may approve a trench to remain open overnight in low-volume traffic areas. This allows a Contractor to avoid backfill and re-excavation operations in the area directly surrounding the end of a pipe. The Contractor assumes all responsibility for the open trench and safety-protection measures.

7-09.3(7)B ROCK EXCAVATION

The section is revised by replacing sentence 2 of paragraph 1 with the following:

Ledge rock, boulders, or stones shall be removed to provide a clearance of 6 inches under the pipe.

7-09.3(9) BEDDING THE PIPE

The section is revised by replacing sentence 1 and 2 with the following:

The Contractor shall install pipe zone bedding material Detail A-19. Pipe zone bedding

material shall conform to Section 9-03.12(3) or Section 9-03.22 for pipes installed above groundwater and above seasonal groundwater zones. Pipe zone bedding material shall conform to Section 9-03.12(4) for pipes installed in groundwater or in seasonal groundwater zones.

7-09.3(11) **COMPACTION OF BACKFILL**

The section is revised by replacing the second sentence of paragraph 2 with the following:

In such cases, the backfill material shall be placed in successive layers not exceeding (18) eighteen inches in loose thickness, and each layer shall be compacted with mechanical tampers to the density specified herein.

7-09.3(17) **LAYING DUCTILE IRON PIPE WITH POLYETHYLENE ENCASEMENT**

The section is replaced with the following:

The Contractor shall lay all ductile iron pipe, valves, and fittings with a polyethylene encasement installed in accordance with AWWA C105.

7-09.3(19) **CONNECTIONS**

7-09.3(19)A **CONNECTIONS TO EXISTING MAINS**

The section is revised by replacing paragraph 1, 2, and 5 with the following:

Method 1-Isolation

The Contractor shall not connect new water mains to existing water mains until a satisfactory bacteriological report has been received by the Engineer and the new water main has passed the hydrostatic pressure test. A backflow prevention assembly that has been authorized by the Public Works Water Director shall be used on the supplying water line when the new water main is filled during disinfection and flushing operations.

Method 2-Lockout

Water mains may be connected to existing water mains prior to passing a bacteriological test provided that the following conditions are met:

1. All materials used in the connection shall be disinfected. The interiors of all pipe and fittings including couplings and sleeves shall be swabbed or sprayed with 1% hypochlorite solution before they are installed.
2. The Contractor shall install a new isolation valve to separate the new main from

the existing main. However, an existing valve may be used as the isolation valve, provided that no services are installed between the existing valve and the point of connection. Existing valves are not guaranteed by the City. Where the Contractor uses an existing valve as an isolation valve, and the existing valve does not hold the required test pressures for a new water main, the Contractor shall replace the existing valve with a new valve that holds the required pressure.

3. The isolation valve shall only be operated by Public Works personnel and shall have a lockout installed on the valve to assure no unauthorized person operates the valve.
4. The new main shall be vented to the atmosphere whenever the valve is open. These procedures are to prevent any backflow from the new main due to back pressure.

If an unsatisfactory bacteriological test report is obtained, the valve shall remain closed and the new main shall be disinfected by injection of a chlorine solution at a location near the valve.

Connections and taps to existing water mains shall be made by Public Works unless otherwise authorized by the Public Works Director. The Contractor shall contact the Public Works at least (48) forty-eight hours prior to making the connection or tap. The Contractor shall submit a list of materials to the Engineer, prior to excavation, that includes fittings, valves, tapping tees, and other items required for the connection. The Contractor shall furnish all labor, equipment, materials, excavation, backfill, and compaction, required to connect to the existing main; however, the actual connection or tap shall be made by Public Works personnel. However, when the connection is being made to a water main stub that is not in service, the connection may be made by the Contractor provided that the Public Works is present.

Cut in connections shall not be made on Fridays, holidays or weekends. All tapping sleeves and tapping valves shall be pressure tested prior to making connection to existing mains. Taps are to be made by City personnel (fee is required).

When the work requires an interruption of service the affected customers shall be notified in advance. The Public Works Director, Engineer, and Contractor shall mutually agree upon a date and time for the work to be performed. The schedule shall allow ample time for the Contractor to mobilize labor, materials, and equipment; and for the Contractor to notify all affected customers.

7-09.3(20) DETECTABLE MARKING TAPE

The section is replaced with the following:

Marking tape shall be placed over all water pipes including service lines. The Contractor shall install the tape approximately (2) two feet above the top of the line for the full length of the line. Marking tape shall meet the requirements of Section 9-15.18.

7-09.3(21) CONCRETE THRUST BLOCKING

The section is revised by replacing paragraph 1 with the following:

Portland Cement Concrete thrust blocking shall be installed at all bends, tees, dead ends, and crosses in accordance with the details and as shown on the Construction Plans. Portland Cement Concrete thrust blocking shall meet the requirements of Section 6-02. Hydrants shall be restrained in accordance with Section 7-14.3(2) A. All reducers shall be restrained in accordance with the details, as shown on the Construction Plans, and as authorized by the Engineer.

7-09.3(22) BLOWOFF ASSEMBLIES

The section is supplemented with the following:

(2") two-inch blow off assemblies shall be installed at the terminus of all dead-end water mains. Blow offs utilized by the Contractor for flushing the water main shall be sufficient size to obtain (2.5') two and one-half feet per second velocity in the main. Temporary blow-offs shall be removed and replaced with a suitably sized watertight brass plug.

7-09.3(23) HYDROSTATIC PRESSURE TEST

The section is supplemented with the following:

A successful pressure test (225 psi for 30 minutes) two hundred and twenty-five psi. shall be performed by the Contractor within 30 days of a satisfactory bacteriological sample, otherwise an additional satisfactory bacteriological sample shall be taken.

After the pipe is filled and all air expelled, it shall be pumped to a test pressure of 225 psi or the pressure classification of the pipe, whichever is less. Test pressure shall be maintained for a period of not less than 30 minutes to ensure the integrity of the thrust and anchor blocks. The Contractor/Developer is cautioned regarding pressure limitations on butterfly valves. All tests shall be made with the hydrant auxiliary gate valves open and pressure against the hydrant valve. Hydrostatic tests shall be performed on every complete section of water main between two valves, and each valve shall withstand the same test pressure at (15) fifteen-minute increments, as the pipe with no pressure active in the section of pipe beyond the closed valve.

7-09.3(23)A TESTING EXTENSIONS FROM EXISTING MAINS

The section is deleted.

7-09.3(23)B TESTING SECTION WITH HYDRANTS INSTALLED

The section is deleted.

7-09.3(23)C TESTING HYDRANTS INSTALLED ON EXISTING MAINS

The section is deleted.

7-09.3(24) DISINFECTION OF WATER MAINS

The section is supplemented with the following:

When a pressure test fails, and any portion of the piping system is taken apart or replaced, the Contractor shall re-chlorinate the water main as directed by the Engineer.

If a section of pipe has not passed a pressure test within 30 days of a satisfactory bacteriological sample, then the line shall be flushed and re-sampled before additional pressure tests shall be allowed.

The following section (7-09.3(25)) is added:

7-09.3(25) TRACER WIRE

A solid copper tracer wire shall be taped, no further than ten (10) feet increments, to the top of all PVC water mains installed and to all service lines between the water main and the water meter. The wire installation shall conform to the details.

7-12 VALVES FOR WATER MAINS

7-12.3 CONSTRUCTION REQUIREMENTS

The section is supplemented with the following:

The Contractor shall replace existing valve boxes with new valve boxes that are provided by the Public Works as directed by the Engineer.

Every cross shall have no less than three (3) three valves, every tee shall have no less than two (2) two valves, and every elbow not within (400) four hundred feet from a valve shall have one valve. An in-line valve shall be installed on straight runs of pipe every (400) four hundred feet.

When connecting to an existing water main with a tapping sleeve and valve, additional valves are not required to be installed on the existing main.

All valve marker posts shall be painted (Blue) and marked with the distance to valve being referenced.

One sampling station is required per development. Additional sample stations required shall be directed by City Engineer or Public Works Director.

Contractor shall request the Public Works Director approval prior to any water shut-off or turn-on, affecting the water system, a minimum of 48 hours in advance. The Public Works Department shall operate all valves in existing service mains.

7-14 HYDRANTS

7-14.3 CONSTRUCTION REQUIREMENTS

7-14.3(1) SETTING HYDRANTS

The section is revised by replacing sentence 1 of paragraph 1 with the following:

Hydrants shall be constructed and installed in accordance with the Hydrant Assembly Detail. In areas without sidewalks, hydrants shall be installed to the elevation as authorized by the Engineer. Hydrants shall be located and oriented as required or authorized by the Adams County Fire District 5. Where a hydrant is required at an intersection, it should be located at Point of Tangent. Construction Plans with on-site fire hydrants shall be approved by the City Engineer prior to installation.

7-14.3(2) HYDRANT CONNECTIONS

The section is replaced with the following:

Hydrant laterals shall consist of a section of 6-inch pipe from the main to the hydrant and shall include an auxiliary gate valve set vertically and placed in line in accordance with the details. Bell and spigot connections and mechanical joints shall be installed with concrete thrust blocks.

7-14.3(2)A HYDRANT RESTRAINTS

The section is replaced with the following:

Hydrants shall be restrained in accordance with the details and as shown on the plans.

7-14.3(2)B AUXILIARY GATE VALVES AND VALVE BOXES

The section is replaced with the following:

Auxiliary gate valves and valve boxes shall be installed in accordance with Section 7-12.

7-15 SERVICE CONNECTIONS

7-15.1 GENERAL

The section is replaced with the following:

This Work consists of installing the service connections from a municipal or private main to the water meter for the premises served. Service connections for commercial, industrial, and residential premises are included in the Work.

Commercial service lines between the water main and the water meter shall be 1-inch minimum with a (1) one-inch meter (no joints).

Meter services and meter boxes shall be set to final grade and all adjustments shall be made prior to final pressure testing of the system.

All new service connections shall comply with the most recent version of "Accepted procedure and practice in Cross Connection Control Manual" as produced by EPA. A copy of such is available for review at the Public Works office.

7-15.3 CONSTRUCTION REQUIREMENTS

The last sentence of paragraph 4 is replaced with the following:

The Contractor shall not commence work that involves interruption of water service until all affected customers have been notified (24) twenty-four hours in advance by Public Works of the scheduled water service interruption.

The last sentence of paragraph 5 is replaced with the following:

All fittings, appurtenances, and other miscellaneous materials on the sections of existing pipe that have been removed shall become the property of the Contractor, except for the meter and all items determined by the Engineer as salvageable.

The section is supplemented with the following:

The excavation for the vault shall be large enough to allow room for compaction of

backfill. The vault shall be set on (6) six inches of select backfill compacted to (95) ninety-five percent of maximum density. Backfill material that is placed within (2) two feet of the structure shall be free of rocks that are larger than (4) four inches in diameter; and native backfill material that does not meet this requirement shall be replaced with select backfill.

The Contractor shall schedule construction operations so that water service customers are not without water for more than (4) four consecutive hours.

The Public Works or Engineering shall inspect the following items prior to meter installation:

- a. All water service lines that are installed in Municipal right-of-way or easements.
- b. All water service lines that are shown on Construction Plans.
- c. All water service lines outside the corporate limits, served with City water, that are installed outside the building envelope.

The Building Department shall inspect the following items prior to meter installation:

- a. All water service lines installed in the corporate limits, between a building and existing water service line, outside the right-of-way or municipal easement.

The following section (7-15.3(2)) is added:

7-15.3(2) SERVICE METER

Public Works shall provide and install service meters at prices established by City ordinance.

Service meter assemblies that are (2") two inches and smaller, and connected to municipal water mains, shall be installed behind the sidewalk within the right-of-way, at locations authorized by the Public Works Director.

All water services greater than 2-inches shall be installed out of the right-of-way, at locations as shown on the Construction Plans or authorized by the City Engineer. Residential water service pipe shall be one-inch K copper with no joints.

All water meter services must be placed behind full height curbs. Service meters that are within the traveled way in shall be installed in traffic-rated tile/vaults.

All water service meters shall be in a separate tile or vault, regardless of whether the tile or vault is municipal or private. Multiple meters are not authorized for installation in the same vault or tile.

The following section (7-15.3(3)) is added:

7-15.3(3) WATER/SEWER CROSSINGS

Where water mains and sewer mains cross, the Work shall be constructed in accordance with current Washington State Department of Ecology requirements.

The following section (7-15.3(4)) is added:

7-15.3(4) BEDDING THE PIPE

Pipe zone bedding material shall conform to the requirements of Section 7-09.3(9).

The following section (7-15.3(5)) is added:

7-15.3(5) BACKFILLING TRENCHES

Backfill shall conform to the requirements of Section 7-09.3(10).

The following section (7-15.3(6)) is added:

7-15.3(6) COMPACTION OF BACKFILL

Compaction of trenches shall conform to the requirements of Section 7-09.3(11).

7-17 SANITARY SEWERS

The section is revised by changing the title as follows:

7-17 GRAVITY SANITARY SEWERS

7-17.2 MATERIALS

The section is revised by replacing the first paragraph with the following:

Pipe used for gravity sanitary sewers can be ductile iron (rigid) or PVC (thermoplastic).

The section is revised by replacing the fourth paragraph with the following:

Materials shall meet the requirements of the following sections:

Solid wall PVC Sanitary Sewer Pipe	9-05.12(1)
Ductile Iron Sewer Pipe	9-05.13

7-17.3 CONSTRUCTION REQUIREMENTS

The section is supplemented with the following:

All pipe shall have a minimum of (72) seventy-two inches of cover.

The sewer main shall run in alleys when at all possible or on street centerline. The sewer main shall maintain a minimum 10-foot horizontal separation from proposed or existing water mains.

All gravity sewer pipe shall be bedded with pea gravel or other material approved by the Public Works Director. The PVC pipe shall be bedded from a depth of four inches below the pipe to (12) twelve-inches above the pipe. The bedding material shall extend across the full width of the trench and shall be compacted under the haunches of the pipe.

The maximum distance between manholes shall be (400') four hundred feet unless specifically approved otherwise by the City Engineer.

All gravity sewer mains shall be installed at the minimum grade allowed by WSDOE unless evidence shows that other properties will not be served by the installation of the deeper sewer main.

The ends of all new gravity sewer mains shall terminate with a manhole.

7-17.3(2) CLEANING AND TESTING

7-17.3(2)A GENERAL

The section is revised by replacing paragraph 1 with the following:

All gravity sewer pipe and appurtenances shall be tested after backfilling, in accordance with Section 7-17.3(2) F.

All gravity sewer mains shall be thoroughly cleaned by a method authorized by the Engineer.

The section is supplemented with the following:

7-17.3(2)F LOW PRESSURE AIR TEST FOR SANITARY SEWERS CONSTRUCTED OF NON-AIR PERMEABLE MATERIALS

The section is replaced with the following:

All gravity sewer and appurtenances shall be tested at (5) five psi for (5) five minutes.

An acceptable test shall not show any visible pressure loss on the gauge. The gauge shall be calibrated to a maximum of (30) thirty psi. At completion of the test, the pressure shall be released so that the gauge may be verified to return to zero psi.

7-17.3(2)H TELEVISION INSPECTION

The section is replaced with the following:

All municipal gravity sewer and storm water mains shall be inspected using a television camera. The Contractor shall provide copies of the video inspections to the Engineer. Video inspections shall be on format that can be downloaded on the city's computers for viewing.

All video inspections shall include the following information on the video:

- a. The name of the project and the name of the Contractor.
- b. The name of the street and the cross street if applicable.
- c. The beginning and ending manhole numbers, as referenced to the approved construction plans.
- d. The direction that the camera is traveling (either upstream or downstream).
- e. The distance shall always be shown on the video inspection, from the beginning manhole, as referenced to 0.0 feet for the beginning manhole.
- f. For side services, the camera shall stop and video inside the service connection. The distance from the beginning manhole to each service connection shall be shown on the video inspection.
- g. For each manhole, the camera shall perform a full video inspection of the inside of the manhole.
- h. All abnormal conditions shall be noted, including repairs, debris, fractures, bellies, and standing water. Where abnormalities are noted, the Contractor shall be on notice that the pipe may not be in acceptable condition until repairs are completed, and the main is re-televised.

The television inspection shall be completed after the subgrade is prepared, and the Contractor shall not perform paving operations until the Engineer has reviewed video inspection reports and determined that the sanitary sewer lines are in acceptable condition.

All costs to provide video inspections shall be borne by the contractor, and the City will not provide television inspection services on sewer lines that are not yet accepted by the City.

7-18 SIDE SEWERS

The section is revised by replacing the title with the following:

7-18 BUILDING SEWERS

7-18.2 MATERIALS

The section is supplemented with the following:

Detectable Marking Tape

9-15.18

7-18.3 CONSTRUCTION REQUIREMENTS

7-18.3(1) GENERAL

The section is supplemented with the following:

All side service sewer lines shall be constructed in accordance with Public Works Design Standards. Building sewers outside the corporate limits connecting to a tributary system to the City's Waste Water Treatment Plant shall require a right-of-way permit from the City. All new building sewer lines shall be connected to the POTW downstream from a manhole.

The following building sewers shall be inspected by the City Engineer prior to service:

1. All building sewers that are installed in right-of-way or easements.
2. All building sewers that are shown on Construction Plans.
3. All building sewers outside the corporate limits, served with City sewer, that are installed outside the building envelope.

The following building sewers shall be inspected by the Building Official prior to service:

1. All building sewers that are installed in the corporate limits, between a building and existing building sewer line stub, outside the right-of-way or municipal easement.

Building sewer locations shown on the Construction Plans are subject to relocation in the field by the Engineer.

Slopes for building sewers within the right-of-way shall not be less than (1/4") one-quarter inch vertical to (1) one foot horizontal. However, where (6) six-inch diameter or larger service pipe is allowed to accommodate larger service flows, slopes may be reduced on building sewers as allowed by WSDOE and as authorized by the Engineer. Slopes for building sewers outside of the right-of-way shall be as authorized by the Building Official.

7-18.3(5) END PIPE MARKER

The section is replaced with the following:

The Contractor shall mark the location of the end of the building sewer with a treated 2x4, if the building sewer will not extend to building connection when the building sewer is installed.

The following section (7-18.3(6)) is added:

7-18.3(6) DETECTABLE MARKING TAPE

The Contractor shall install detectable marking tape over all side sewer lines. The tape shall be placed approximately (2') two feet above the top of the line and shall extend the full length of the pipe. Where the building sewer does not extend to a building connection when the building sewer is installed, the tape shall be tied off to the treated 2x4 marking the end of building sewer.

7-20.3(3) TESTING

The Contractor shall test the force main in accordance with Section 7-09.3(23), Hydrostatic Pressure Test; except that the test pressure shall be (150') one-hundred-fifty psi in excess of that in which they will operate, but not less than 225 psi.

7-20.3(4) LAYING DUCTILE IRON PIPE AND FITTINGS WITH POLYETHYLENE
ENCASEMENT

Ductile iron pipe and iron pipe fittings shall be laid with polyethylene encasement. Polyethylene encasement shall be installed in accordance with AWWA C105.

7-20.3(5) SERVICE METER FOR WASTEWATER

Service meters may be required by the City prior to connecting to the POTW in situations where the volume of sewage cannot be determined by water usage and may be authorized by the City when requested by the Owner in situations where the volume of sewage is substantially less than water usage. The Contractor shall provide and install service meters whenever sewage meters are required or authorized by the City. All wastewater meters should include a bypass line, with locking ball valves, to allow the Owner to remove a wastewater meter for inspection, replacement, or service without stopping the wastewater flow to the POTW. All Work shall be in accordance with Construction Plans and details.

7-20.4 CONSTRUCTION REQUIREMENTS

7-20.4(1) IRRIGATION SYSTEMS

7-20.4(2) DESCRIPTION

The section is supplemented with the following:

The irrigation system includes bubblers, valve boxes, piping, drain pipes, poly pipe, quick coupling devices, double check-valve backflow assembly, Y strainer, valves, electric control valves, battery operated controller with hand-held programmer, 30-inch water meter tile with cast iron ring and cover, and all fittings and miscellaneous items to complete the installation of the irrigation system in accordance with the Plans.

7-20.4(3) MATERIALS

The section is supplemented with the following:

Double Check-valve Backflow Assembly 9-15.11

Unless otherwise approved or required by the Public Works Director, the main shall be C900 or C905 PVC (purple pipe) as per section 7-09.2. The minimum size for all main lines shall be (6") six-inches, unless specifically written approved stating otherwise.

Service lines shall be 1" tubing SDR-9 CTS PE4710 and stainless steel 50 series inserts with copper compression fittings.

7-20.4(4) CONSTRUCTION REQUIREMENTS

The section is supplemented with the following:

The Contractor shall coordinate tie-in work to existing irrigation system with the Public Works Director (509) 488-6997.

City of Othello's non-potable water is defined as: water that is not treated to approved drinking water standards and is not suitable, nor intended for human consumption (to include drinking, bathing, showering, cooking, dishwashing, or maintaining oral hygiene), but is produced and delivered to users for irrigation, commercial and industrial uses. Non-potable water may include treated industrial wastewater (reclaimed water), raw (untreated) groundwater, and raw (untreated) surface water.

A. Authorized Uses: Non-potable water is authorized for irrigation, per OMC 12.44.060:

- Landscape irrigation of areas accessible to the public including, but not limited to, parks, greenbelts, golf courses and common areas at residential building developments (townhouses, condominiums, and apartments), commercial/ business parks, school

- grounds, and other similar complexes.
- Resident-controlled landscape irrigation
 - Non-residential controlled landscape irrigation at single family homes (i.e. Homeowners Associations).
 - Agricultural irrigation including non-food crop and silviculture.
 - Potential industrial uses: industrial processes, wash water applications, and non-discharging construction and road maintenance activities.
 - Other uses as approved on a case-by-case basis by Othello Public Works Director.
- B. Non-Authorized Uses: Non-potable water is not authorized for:
- Fire protection
 - Potable uses
 - Other uses not specifically approved by the City of Othello.
- C. All irrigation systems for landscaped areas adjacent to the existing or future recycled non-potable water alignment shall be designed and installed to allow for the current and future use of non-potable water. The Owner/Developer shall be responsible for all costs incurred in designing and installing the pressure irrigation systems.
- a. Mainline distribution piping shall be minimum (6) six-inches in diameter. Computations and other data used for design of the non-potable water system shall be submitted to the City for approval. Computations and other data used for design of the non-potable water system may be required for City approval. Hydraulic design may include, but is not limited to, main line installations, side service laterals, pumps, and controls.
 - b. Mainline Pipe Cover and Crossing Clearance: pipes shall be buried at 24 inches below the final grade surface and have a minimum pipe crossing clearance with other utilities of (1') one foot. Where the minimum clearance cannot be met, encasement or cap shall be designed by the design engineer for approval by the City's Engineer.
 - c. Air Relief and Blow-off Valves: Provide appropriate air relief valves (pressure air release at all high points to vent; air and vacuum to vent air while filling and to allow air to re-enter while draining to prevent collapse, etc.) at all high points in the pipe line.
 - d. Separation Requirements: All non-potable water service lateral and meters must be at least 10 feet from the nearest potable water facility, including pipelines, meters and hydrants. Designers should check to see that laterals and meters that serve their site meet these requirements.
 - e. Backflow Prevention: Since non-potable water is not used for drinking purposes, backflow protection is not normally necessary on non-potable water

systems. However, Public Works may require backflow protection on the proposed system if it is determined that there is a backflow hazard on-site which threatens the integrity of the distribution system.

Backflow devices are required as part of a potable water service connection to sites where non-potable water is available. At premises where both non-potable water and potable water are presents in separate piping systems with no interconnecting, a reduced pressure (RP) principal backflow prevention device must be located as close as practicable to the downstream side of every potable water meter.

- f. Hose Bibs are not allowed on non-potable water systems.
- B. All non-potable water system transmission and distribution piping spanning channels, highways, railroads, and other physical barriers shall be contained in casings.
- C. The submission of the final plat shall include a complete set of O&M's for the system (if applicable).
- D. Documentation of the design of the non-potable water system distribution within any right-of-way, or proposed city right-of-way, shall be with plans signed by a Professional Engineer licensed in the state of Washington.
- E. The system shall be provided with a drain(s) or blow-off to provide for winterization. Blow-off valves can also be used to provide a means to provide for removing water from the system for winterization.
- F. Material and installation specifications shall contain appropriate requirements that have been established by the industry in its technical publications, such as ASTM, AWWA, WPCF, and APWA standards. Requirements shall be set forth in the specifications for the pipe and methods of bedding and backfilling so as not to damage the pipe or its joints.
- G. Except as otherwise noted herein, all work shall be accomplished as recommended in applicable American Water Works Association (AWWA) Standards, and according to the recommendations of the manufacturer of the material or equipment concerned.
- H. The location of mains, valves, hydrants, and principal fittings including modifications within the proposed ROW shall be staked by the Developer. No deviation shall be made from the required line or grade. The Contractor shall verify and protect all underground and surface utilities encountered during the progress of this work.
- I. Prior to final inspection, all pipelines shall be tested at (150) one-hundred-fifty psi for (30) thirty-minutes.
- J. All non-potable water controllers, valves, outlets, etc. shall be tagged or signed with

the following words: “NON-POTABLE WATER – DO NOT DRINK” or similar.

K. Blowoffs and drain valves shall be painted purple and labeled “NON-POTABLE”.

7-20.4(5) INSTALLATION

The section is revised by deleted the first paragraph

7.20.4(6) Flushing and Testing

The section is supplemented with the following:

All main lines shall be cleaned and hydrostatically tested per current applicable AWWA and WSDOT/APWA Standards prior to acceptance of the Work. A water hydrant meter shall be required and procured from the City for all water utilized for flushing pipelines. All pumps, gauges, plugs, saddles, corporation stops, miscellaneous hose and piping, and measuring equipment necessary for performing the test shall be furnished, installed and operated by the Contractor.

The main line shall be backfilled sufficiently to prevent movement of the pipe under pressure. All thrust blocks shall be placed, and time allowed for the concrete to cure before testing. Where permanent blocking is not required, the Contractor shall furnish and install temporary blocking. Main line testing may be completed with the side service corp stop closed.

As soon as pipe is secured against movement under pressure, it may be filled with water. Satisfactory performance of air valves shall be checked while the line is filling.

Service lines 50 feet and less shall be pressurized to 1.5 times the working pressure and visually inspected for leaks.

PEX main line and service line filling and testing:

The pipe should be filled slowly, limiting the flow to low velocities that prevent surges and air entrapment. Valves at high points should be open to allow air to escape as the water level increases inside the pipe. To prevent damage to down-stream valves, the piping should be thoroughly flushed prior to testing. Visually confirm all connections are properly made per manufacturer’s installation guidelines.

1. Ensure that all components, fixture and equipment not rated for the test pressure are isolated from the test system.
2. Ensure that all other thermoplastic piping materials are isolated from the test system.

3. Fill the system slowly with potable water, limiting the flow to low velocities that prevent surges and air entrapment.

The Contractor shall request inspection a minimum of 48 hours prior to the Contractor's scheduled need. Inspections shall be required for the following items of work:

1. Pipe and bedding installation
2. Backfill and compaction
3. Thrust Restraint and thrust block placement
4. Pressure testing.

7-20.4(7) IRRIGATION WATER SERVICE

The section is replaced with the following:

All services shall meet standard drawings NP-1 Sheet 1.

7-20.4(8) IRRIGATION ELECTRICAL SERVICE

The section is deleted.

DIVISION 8 MISCELLANEOUS CONSTRUCTION

8-01 EROSION CONTROL AND WATER POLLUTION CONTROL

8-01.1 DESCRIPTION

The section is supplemented with the following:

A stormwater construction permit is required from WSDOE prior to construction for all construction projects that are one acre or larger if stormwater from the construction site could discharge to surface water, associated wetlands, or the City's stormwater system.

8-01.3 CONSTRUCTION REQUIREMENTS

8-01.3(9) SEDIMENT CONTROL BARRIERS

8-01.3(9)D INLET PROTECTION

The section is revised by replacing paragraph 1 with the following:

Inlet protection shall be performed below grade. The Contractor shall install inlet protection devices for catch basins prior to clearing, grubbing, and or earthwork.

8-02 ROADSIDE RESTORATION

8-04 CURBS, GUTTERS, AND SPILLWAYS

8-04.1 DESCRIPTION

The section is supplemented with the following:

Replacement curb and gutter shall match the typical dimensions of adjacent curb and gutter unless otherwise directed by the Engineer.

8-04.3 CONSTRUCTION REQUIREMENTS

8-04.3(1) CEMENT CONCRETE CURBS, GUTTERS, AND SPILLWAYS

The section is revised by replacing paragraph 1 with the following:

Portland Cement Concrete curb, curb and gutter, and spillway shall be constructed with air entrained Portland Cement Concrete Class 3000 conforming to the requirement of Section 6-02.

The section is revised by replacing sentence 1 of paragraph 3 with the following:

The foundation shall be watered thoroughly before the Portland Cement Concrete is placed, and the Portland Cement Concrete shall be well tamped and spaded in the forms. Vibration is not authorized.

The section is revised by replacing sentence 4 of paragraph 3 with the following:

The top, face, and gutter surfaces of the curb shall receive a light brush finish, parallel to the roadway.

Any curb and gutter not acceptable, in the opinion of the City, because of damage or defacement, shall be removed and replaced by the Contractor at the Contractor's expense. Sacking or grinding shall not be considered an acceptable means for repairing unacceptable sections.

The section is revised by replacing sentence 1 and 2 of paragraph 4 with the following:

The Contractor shall cut (1") one-inch deep control joints in the curb and gutter at (10') ten-foot intervals. However, some flexibility is allowed in the placement of joints so that joints in the curb may line up with the joints in the sidewalk or at transitions, as directed by the Engineer. Full-depth mastic shall be installed at 100-foot intervals and at

points of curvature. However, mastic shall not be installed in depressed curb for driveways or curb ramps.

The section is supplemented with the following:

The Contractor shall provide forms that are clean and well-oiled prior to placement. The top of the form shall not depart from grade more than (1/4") one-quarter inch when checked with a (10') ten foot straight edge and the alignment shall not vary more than (3") three inch in (10') ten feet, with the exception of curbs installed on curves. Curbs installed along curves shall not be constructed of straight curb segments.

The Contractor shall remove pavement adjacent to the existing curb that is being removed for replacement. The Contractor shall remove enough pavement adjacent to the curb to allow for mechanical compaction of successive HMA layers, and additional pavement may be required to be removed to correct depressions or critical slopes in the pavement adjacent to the curb, as directed by the Engineer. HMA patches shall be placed in accordance with Section 5-06. However, the Contractor may not be required to remove any pavement for curb replacement provided that the edge of pavement is not disturbed during curb removal, the adjacent pavement is in good condition, and the adjacent pavement has the required grade for HMA at the completion of the curb replacement.

The Contractor shall remove full (10') ten-foot sections of the existing curb when removing and replacing curbs and gutters. Except, the Contractor may salvage portions of curb adjacent to the curb that has been removed by saw-cutting the damaged ends, provided that the salvaged portion is completely intact, has not been moved or displaced by removing curb or sidewalk adjacent to it, and at least (6') six feet of salvageable curb remains. The Contractor shall remove additional curb as directed by the Engineer if the adjacent curb has been damaged at the point of connection. The Contractor shall install (2) two- (12") Twelve-inch, No. 4 rebar into each existing curb in accordance with the details.

As an option to removing curb to install a new driveway approach in an existing curb, the Contractor may sawcut the face of curb to the shape of a standard curb cut. The back-of-curb shall not be greater than 1.5 inches above the flow line for driveway cuts.

Portland Cement Concrete shall meet the cold-weather protection requirements specified in Section 8-14.3(3).

8-06 CEMENT CONCRETE DRIVEWAY ENTRANCES

The entire section is replaced with the following:

Driveways shall be constructed in accordance with Section 8-14.

8-13 MONUMENT CASES

8-13.1 DESCRIPTION

The section is replaced with the following:

This work shall consist of furnishing and placing iron pipe, brass monument, adjustment sleeve, monument case, and cover, in accordance with the details.

The following section (8-13(3)) is added:

8-13.31 NEW MONUMENTS

The materials and method of construction shall conform to the requirements specified herein and as indicated in Section 8-13 of the WSDOT Standard Specifications. The following procedure shall be followed for the placement of new monuments as well as the replacement of disturbed existing monuments:

The Developer's Surveyor will reference all monuments that will be removed or destroyed during construction prior to their removal or destruction. The Developer's Surveyor will complete and file all documentation required for the temporary removal of said monuments.

After the Contractor constructs the road, the Developer's Surveyor will set two (2), two - (2') foot long "straddles" at the monument locations designated on the Plans.

The Contractor shall install the new monument cases, complete with Schedule 40 galvanized steel pipes and (2") two-inch diameter brass caps. The monument case, cover, pipe, and brass cap will be furnished and set in concrete, and patched with HMA, by the Contractor.

The Developer's Surveyor will stamp the brass caps with "cross hairs," or some other such industry-accepted mark, to indicate the point that was removed is now replaced. The Developer's Surveyor will also affix his/her Washington State PLS registration number to the brass caps. The Developer's Surveyor will then file all required documentation indicating that the monument has been reestablished.

8-14 CEMENT CONCRETE SIDEWALKS

8-14.1 DESCRIPTION

The section is replaced with the following:

The work shall consist of constructing Portland Cement Concrete sidewalks, driveways, slabs, and bike paths in accordance with these specifications and in conformity with the lines, grades, thicknesses, and typical cross-sections shown in the Construction Plans or as established by the Engineer.

8-14.2 MATERIALS

The section is revised by replacing the first sentence of paragraph 2 with the following:

Detectable warning surfaces for curb ramps shall meet the requirements of Section 9-21.4.

8-14.3 CONSTRUCTION REQUIREMENTS

The section is supplemented with the following:

Sidewalks, curbs, driveways, and ramps that are removed and replaced to eliminate hazards or to repair underlying utilities shall be reconstructed to match the slope and grade of the existing concrete surfaces adjacent to the repair. All sidewalks, curbs, driveways, and ramps that are removed and replaced to accommodate revisions to existing driveways or ramps shall be reconstructed such that the entire driveway or entire ramp is constructed to current standards.

8-14.3(3) PLACING AND FINISHING CONCRETE

The section is revised by replacing paragraph 2 with the following:

The Contractor shall brush the surface of the sidewalks with a stiff bristled broom in a direction perpendicular to the curb, after troweling and after edging.

The section is revised by replacing the third, fourth, and fifth paragraphs with the following:

Control joints shall be spaced in accordance with the details and as directed by the Engineer. All control joints shall be perpendicular to the curb.

The Contractor shall place expansion joints every (20') twenty to (30') thirty feet, to align with the spacing for control joints, as directed by the Engineer. Expansion joints shall not be installed in driveways or ramps. Expansion joints shall be installed perpendicular to the curb, for the full depth of concrete.

The Contractor shall not spray water on the surface of the concrete for finishing; however, a very light mist may be acceptable by the Engineer.

The Contractor shall immediately cover all concrete with plastic if rain begins to fall

before the concrete has set up. Any sidewalks that have been subjected to rain prior to setting may be rejected.

Concrete finishes that have a vertical difference of (1/4") one-quarter inch or more between panels shall be rejected.

The Contractor shall remove one full section, or more, of existing sidewalk when removing and replacing sidewalks; except, the Contractor can sawcut the adjacent panels of sidewalk and salvage portions of sidewalk panels provided that the salvaged portion is completely intact, it has not been moved or displaced by removing curb or sidewalk panels adjacent to it, and it is (3') three feet or longer. All saw-cuts shall be perpendicular to the curb and shall extend to the back of sidewalk. The Contractor shall remove additional sidewalk as directed by the Engineer if adjacent sidewalk panels have been damaged.

Cold Weather Protection

To achieve adequate curing on sidewalks, curb, and driveway approaches, surface temperature of the Portland Cement Concrete shall be maintained by the Contractor above (50°F) fifty degrees Fahrenheit for (3) three days. When the National Weather Bureau predicts temperatures below (35°F) thirty-five degrees Fahrenheit for the (72) seventy-two-hour period after Portland Cement Concrete is placed, the Contractor shall provide a thermometer on the finish Portland Cement Concrete surface, to record the lowest temperature. The Contractor shall maintain the thermometer and cold weather protection for the finished Portland Cement Concrete until the Portland Cement Concrete has been maintained above (50°F) fifty degrees Fahrenheit for three (3) days. The cure period does not need to be (3) three continuous days but shall consist of (3) three or more continuous periods of (24) twenty-four hours or greater. If the lowest surface temperature of the concrete drops below (32°F) thirty-two degrees Fahrenheit before the (3) three-day cure period has been achieved, the Portland Cement Concrete may be rejected by the Engineer.

8-14.3(4) CURING

The section is supplemented with the following:

The Contractor may use clear pigment curing compound as an alternative to moist burlap or quilted blankets. The Contractor shall apply clear pigment in accordance with the procedures outlined in Section 5-05.3(13) A. The curing agent shall be applied immediately after brooming; except, between October 1st and March 31st, curing compound shall be applied when recommended by the manufacturer for temperatures encountered.

8-14.3(5) DETECTABLE WARNING SURFACE

The section is revised by replacing the first paragraph with the following:

The detectable warning surface shall be located as shown in the Construction Plans or as directed by the Engineer. Placement of the detectable warning surface shall be in accordance with the manufacturer's recommendation for placement in fresh Portland Cement Concrete, before the Portland Cement Concrete has reached initial set.

The following section (8-14.3(6)) is added:

8-14.3(6) DEPRESSED CURB FOR CURB RAMPS

The Contractor shall construct depressed curbs for curb ramps at intersections where new Portland Cement Concrete curbs are being constructed. The Contractor shall also install depressed curb for an additional ramp across from new ramps at intersections where no existing ramps have previously been constructed, as directed by the Engineer.

The Contractor shall replace depressed curbs for curb ramps that have been installed with a vertical rise of more than (1/2") one-half inch within (3") three inches of the center of the flow line.

8-21 PERMANENT SIGNING

8-21.3 CONSTRUCTION REQUIREMENTS

8-21.3(1) LOCATION OF SIGNS

The section is replaced with the following:

Signs shall be located as shown on the Construction Plans and as directed by the Engineer. The sign locations shown in the Construction Plans are subject to relocation in the field as directed by the Engineer.

8-21.3(2) PLACEMENT OF SIGNS

The section is supplemented with the following:

The Contractor shall install permanent signs as shown on the Sign Installation Detail.

8-22 PAVEMENT MARKING

8-22.1 DESCRIPTION

The section is supplemented with the following:

Optional narrow elongated arrows in FHWA publication Standard Alphabet for Highway Signs and Pavement Markings are not authorized for installation.

8-22.2 MATERIALS

The section is revised by replacing the first sentence with the following:

Material for pavement marking shall be paint or Type B plastic in accordance with Section 9-34. All word, symbol, transverse crosswalk line markings, and stop bars shall be Type B plastic.

8-22.3 CONSTRUCTION REQUIREMENTS

8-22.3(3)E INSTALLATION

The section is revised by replacing the paragraph 2 with the following:

The Contractor shall not apply paint unless the temperatures of both the pavement and the air are greater than (50°F) fifty degrees Fahrenheit. And, when the temperature is less than (60°F) sixty degrees Fahrenheit, paint shall not be applied if the temperatures are decreasing.

The Contractor shall not apply Type B material unless the temperatures of both the pavement and the air are greater than (40°F) forty degrees Fahrenheit. And, when the temperature is less than (50°F) fifty degrees Fahrenheit, Type B materials shall not be applied if the temperatures are decreasing.

DIVISION 9 MATERIALS

The Division is supplemented by including the following prior to Section 9-00:

Submittals for all materials used on the project shall be authorized by the Engineer prior to installation of the item.

9-03 AGGREGATES

9-03.12 GRAVEL BACKFILL

9-03.12(3) GRAVEL BACKFILL FOR PIPE ZONE BEDDING

The section is revised by deleting the final paragraph:

9-03.12(5) GRAVEL BACKFILL FOR DRYWELLS

The section is revised by replacing the gradation requirements as follows:

Sieve Size	Percent Passing
3-inch square	100
2-inch square	0 - 20
4-inch square	0 - 2.0
U.S. No. 200	0 - 1.5

The following section (9-03.22) is added:

9-03.22 SAND PIPE BEDDING

Blow sand, free of rocks larger than 2-inch in diameter and free of organic material, may be used as pipe bedding material above the groundwater.

9-03.3 VACANT

9-04 JOINT AND CRACK SEALING MATERIALS

9-04.1 CRACK SEALING RUBBERIZED ASPHALT

The section is replaced with the following:

Crafco Roadsaver 201 or 221 is the only rubberized crack seal material that is pre-authorized by the City Engineer.

Other materials proposed on the project shall be submitted to the Engineer and authorized by the Engineer prior to use. The Contractor shall submit to the Engineer certification from the manufacturer verifying that the material has been authorized by the WSDOT. The Contractor shall also submit product information describing the Manufacturer's recommendations for application of the product.

9-05 DRAINAGE STRUCTURES AND CULVERTS

9-05.15 METAL CASTINGS

9-05.15(1) MANHOLE RING AND COVER

The section is supplemented with the following:

Authorized ring and covers for City wastewater manholes and City drain manholes or type II catch basins shall be D & L Foundry, A-2000-R1, with "City of Othello" on the cover in accordance with the details.

Authorized ring and covers for private manholes that are connected to the City Sewer shall not have the "City of Othello", include the following:

D & L Foundry (or approved equal) A-2000

9-05.15(2) METAL FRAME, GRATE, AND SOLID METAL COVER FOR CATCH BASINS OR INLETS

The section is supplemented with the following:

The following catch basin frames and covers are authorized for installation:

D & L Foundry I-4432.02(with vane grate)
D & L Foundry I-4432.03(with bi-directional vane grate)

The Contractor shall install bi-directional grates or uni-directional grates as directed by the engineer, or as shown on the plans.

Herringbone grates are not authorized for installation.

9-05.50 PRECAST CONCRETE DRAINAGE STRUCTURES

9-05.50(2) MANHOLES

The section is supplemented with the following:

Ladder rungs shall be co-polymer polypropylene conforming to ASTM 2146-82, type II, grade 43758, with 2-inch diameter, grade 60, steel reinforcing bars.

The Contractor shall provide precast manhole elements with ladder rungs, vertically aligned, such that the completed manhole shall contain a continuous vertical ladder with rungs equally spaced at 12-inches. The lowest rung shall not be more than 16 inches above the shelf, and the uppermost rung shall not be more than 12-inches below the top of cone.

9-05.50(3) PRECAST CONCRETE CATCH BASINS

The section is revised by replacing paragraph 1 with the following:

Precast concrete catch basin construction shall conform to the requirements of Section 9-05.50(1), except that the dimensions shall be in accordance with details.

9-14 EROSION CONTROL AND ROADSIDE PLANTING

9-14.6 PLANT MATERIALS

9-14.6(8) SOD

The section is supplemented with the following:

The maintenance period shall begin on the date the Engineer approves the placed sod and shall continue for (10) ten days. At the end of the maintenance period, the Engineer shall mark all sod for replacement that is not in a healthy, growing condition. All sod marked by the Engineer for replacement shall be removed and replaced by the Contractor at the Contractor's expense. Sod that is replaced shall be of the same mixture and grade as the surviving sod.

Sod shall be mature, densely rooted grass, and shall possess the following characteristics:

- Uniformity
- Acceptable color
- Freedom from weeds and weed seeds
- Adequate sod strength for handling

9-15.11 CROSS CONNECTION CONTROL DEVICES

The section is supplemented with the following:

The irrigation system cross connection control device shall be a double check-valve backflow assembly. The following double check-valve assembly is authorized for installation:

Febco Model 850, 2-inch.

Alternate double check-valve backflow assemblies are not authorized for installation without written approval from the Public Works Director.

Water systems (i.e. sprinkler systems, swimming pools, laboratories, car washes, funeral homes, or at direction of the Building Department and Public Works Department) connected to the public water system shall have backflow prevention as required by WAC 248-54-285.

All fire sprinkler systems that have a fire department connection shall have backflow prevention as required by WAC 248-54-285.

All water systems that have access to a non-potable water system shall have a backflow prevention device on potable service located (3) three to (5) five-feet behind water service.

9-15.18 DETECTABLE MARKING TAPE

The section is revised by replacing the last paragraph with the following:

The width of the tape shall be at least 2 inches.

9-21 RAISED PAVEMENT MARKERS (RPM)

The following section (9-21.4) is added:

9-21.4 DETECTABLE WARNING SURFACES FOR CURB RAMPS

The color of detectable warning surfaces for curb ramps shall be Federal Yellow.

The following detectable warning surfaces are authorized for installation:

Neenah Foundry Company, cast-iron, ADA-Compliant, Truncated-Dome, Detectable Warning Plate, with powder-coated finish.

East Jordan Iron Works, gray-iron, heavy-duty, detectable warning plate, with powder coating RAL 1003 (Product Number 00700585).

9-22 MONUMENT CASES

9-22.1 MONUMENT CASES, COVERS, AND RISERS

The section is supplemented with the following:

Authorized monument case and covers include the following:

D & L Foundry	K-6523
Olympic Foundry	M1015

9-28 SIGNING MATERIALS AND FABRICATION

The following section (9-28.16) is added:

9-28.16 STREET NAME SIGNS

Street name signs shall be two-sided signs. The maximum length shall be 42 inches. The height shall be 9 inches. Sign blanks shall be double-faced, extruded blade.

Letters for street names shall be as follows:

- a. All letters shall be 6-inches tall.
- b. First letters of each word of a street name shall be upper case.
- c. Letters that follow the first letter of a word in a street name shall be lower case.

Letters for designators, such as St (Street), Dr (Drive), Ave (Avenue), Rd (Road), Blvd (Boulevard), Way, and Pl (Place) shall be as follows:

- d. All letters shall be 4-inches tall.
- e. First letters of a designator shall be upper case.
- f. Letters that follow the first letter of a designator shall be lower case.

9-29 ILLUMINATION, SIGNAL, ELECTRICAL

9-29.2 JUNCTION BOXES, CABLE VAULTS, AND PULL BOXES

The section is supplemented with the following:

Junction boxes that are authorized for installation in the sidewalk shall be rated for installation in the sidewalk, shall be authorized by the utility, and shall be authorized for use by the Engineer prior to installation.

9-30 WATER DISTRIBUTION MATERIALS

9-30.3 VALVES

9-30.3(1) GATE VALVES-3 INCHES TO 16 INCHES

The section is replaced with the following:

Gate valves shall be non-rising stem, resilient wedge, conforming to AWWA C509 or AWWA C515. The wedge shall be cast iron, completely encapsulated with urethane rubber. Urethane rubber shall be permanently bonded to the cast iron wedge in accordance with ASTM D429.

9-30.3(4) VALVE BOXES

The section is supplemented with the following:

The following valve boxes are authorized for installation:

Olympic Foundry
Tyler

VB 930
6855 with drop lid

Page 88 of 96

9-30.3(5) Valve Marker Posts

The section is supplemented with the following:

For each valve outside of asphalt, provide a valve concrete pad 24" x 24" x 6" with reinforcing mesh centered over valve box and set to grade.

9-30.3(7) COMBINATION AIR RELEASE & AIR VACUUM VALVES

The section is supplemented with the following:

For sewer line applications, the Contractor shall install air-release valves where shown on the Construction Plans. Air release valves shall be A.R.I. Model D-20, flanged, epoxy-coated valves. Air release valve assemblies shall be constructed in accordance with the details.

9-30.3(8) TAPPING SLEEVE AND VALVE ASSEMBLY

The section is revised by replacing the last sentence with the following:

Tapping sleeves shall be Romac Industries SST, Stainless Steel Tapping Sleeve with Ductile Iron Flange.

The following section (9-30.3(9)) is added:

9-30.3(9) CHECK VALVES

Dresser M and H Style number 259-02, flanged end, with lever, spring, and bronze disk are authorized check valves.

9-30.5 HYDRANTS

The section is revised by changing the title as follows:

9-30.5 FIRE HYDRANTS

The section is supplemented with the following:

The following hydrants are authorized for installation:

WATEROUS WB67250

9-30.5(1) END CONNECTIONS

The section is replaced with the following:

The end connection shall be a mechanical joint meeting the requirements of AWWA C110 and C111.

9-30.5(2) HYDRANT DIMENSIONS

The section is replaced with the following:

Hydrant connection pipe size, inside diameter:	6-inch MJ
Standpipe, inside diameter:	7 inches
Valve opening, diameter:	5.25 inches
Size of auxiliary gate valve:	6 inches
Hose nozzle:	
-number	2
-size	2.5 inch
-thread	National Standard
Length of thread:	1 inch
Pumper nozzle:	
-number	1
-size	4.5 inch
-thread	National Standard with a permanent 5-inch Storz connection, Style S-37, by Red Head Brass, Inc. is an authorized Storz connection
Operating nut:	1.5-inch standard pentagon

Hydrants shall include a weather shield on the operating nut. The fire hydrants shall be painted per Adams County Fire District requirements with two coats of Preservative Brand caterpillar or international yellow paint.

The bonnet shall be painted the same color as the hydrant and the Storz connection shall not be painted.

9-30.5(3) HYDRANT EXTENSIONS

The section is revised by replacing sentence 1 of paragraph 1 with the following:

Hydrant extensions shall have a 7-inch inside diameter, shall be gray cast iron or ductile iron, and shall conform to AWWA standards for such castings.

9-30.6 WATER SERVICE CONNECTIONS (2") TWO INCHES AND SMALLER

9-30.6(1) SADDLES

The section is revised by replacing the second paragraph with the following:

Saddles shall have an FIPT connection.

The following saddles are authorized for installation for 1-inch service lines:

Romac 101S
Ford 101S

The following saddles are authorized for installation for 2-inch service lines:

Romac 202S
Ford 202S

Saddles used on PVC pipe shall be formed for PVC pipe and shall have flat, stainless steel straps. For PVC pipe, provide a saddle that has the pipe O.D. closest to the top of the saddle's O.D. range. The correct Romac saddle sizes for C900 PVC pipe are as follows:

<u>Pipe Size</u>	<u>Diameter Range</u>
6-inch	6.63-6.90
8-inch	8.63-9.05
10-inch	10.00-11.10
12-inch	12.00-13.20

9-30.6(2) CORPORATION STOPS

The section is replaced with the following:

Corporation stops shall be ball valves made of bronze alloy and shall have MIPT on the inlet and outlet. Ford FB500 corporation stops are authorized for 1-inch and 2-inch outlet saddles.

9-30.6(4) SERVICE FITTINGS

The section is supplemented with the following:

Service fittings shall conform to AWWA C-800. All service fittings installed on a service line, between the corporation stop and the meter setter, and on the service side of the setter, shall be compatible and from the same manufacturer.

9-30.6(5) METER SETTERS

The section is revised by replacing paragraphs 3 and 4 with the following:

Meter setters shall be either 1-inch or 2-inch setters for services that are 2 inches and smaller.

All setters shall have iron pipe threads (IPT) on the inlet and the outlet, the same size as the setter. All meter setters that are 2-inches or smaller shall include a locking ball-valve inlet and a single check-valve outlet. Two-inch meter setters shall also include a high, offset bypass.

The following setters are authorized for installation for 2-inch services:

Ford

VBH-74-24W-44-44-Q

9-30.6(7) METER BOXES

The section is replaced with the following:

The following tiles are authorized for installation for 1-inch water services in non-traffic areas:

OLD CASTLE 1324BCF

The following tiles are authorized for installation for 1 ½ to 2-inch water services in non-traffic areas:

1 ½" OLD CASTLE 1730BCF
2" OLD CASTLE 1730BSF

The following traffic-rated tile is authorized for installation for one-inch or two-inch water services in commercial-use and industrial-use traffic areas:

H² Pre-cast Inc. Vault Base VBE3 with lid VLE3-24

Poly-tuff meter tiles are not authorized for installation for any water service.

The following vaults are authorized for water services:

H ² Pre-cast Inc.	Small Meter Vault with traffic top, SMV 9686-TR
Wilbert Vault Company (Spokane)	Vault model number 1901
H ² Pre-cast Inc.	Large Meter Vault with traffic top, LMV 14481-TR

Vaults for water services shall include a six-inch-tall riser with a 6-inch-tall frame and cover.

All vaults shall have a hatch. Hatches shall be USF fabrication H-20 rated hatch model UEZD (33 $\frac{9}{16}$ x 67) or approved equal.

The Contractor shall verify that the vault and meter combination selected can meet the space requirements in accordance with details.

The following section (9-30.7) is added:

9-30.7 WATER SERVICE CONNECTIONS LARGER THAN 2 INCHES

Meters that are larger than (2") two inches shall be as specified by the Public Works Director. The installation shall include an Electronic Remote Transmitter (ERT); handwheel gate valves on each side of the meter; and a bypass that is the same size as the service line, with a handwheel gate valve. All water meters shall measure cubic feet. The Contractor shall provide submittals to the Engineer on all meters and meter installations that are larger than (2") two inches. The Contractor shall not commence work until the submittals have been authorized by the Engineer.

All water services greater than (2") two inches shall be installed out of the right-of-way, at locations as shown on the Construction Plans or authorized by the Engineer.

Service meters that are within the traveled way in commercial-use or industrial-use areas shall be installed in traffic-rated vaults.

The following vaults are authorized for water services:

H ² Pre-cast Inc.	Small Meter Vault with traffic top, SMV 9686-TR
Wilbert Vault Company (Spokane)	Vault model number 1901
H ² Pre-cast Inc.	Large Meter Vault with traffic top, LMV 14481-TR

The Contractor shall verify that the vault and meter combination selected can meet the space requirements of the Public Works Design Standard details.

The following section (9-30.8) is added:

9-30.8 TRACER WIRE

Tracer wire shall be insulated, solid No. 10 copper wire approved for underground installation.

9-33 CONSTRUCTION GEOSYNTHETIC

The section is replaced with the following:

Crown Resources R060 geotextile material is authorized for underground. This includes drywells, underdrain pipe, and French drains.

Phillips Fibers Corporation, SUPAC-4NP geotextile material is authorized for concrete brick pavers.

Geotextile material for subgrade stabilization shall be as authorized by the Engineer.

Geotextile material for overlays shall be as authorized by the Engineer.

9-34 PAVEMENT MARKING MATERIAL

9-34.3 PLASTIC

The section is revised by replacing the first sentence with the following:

White and yellow pavement marking materials shall comply with the Specifications for Type BBPre-formed fused thermoplastic. Type B thermoplastic shall be Premark-Plastic.

DETAIL DRAWING INDEX

TITLE **Detail**

STREET

Typical Street Cross Section	A-1
Typical Alley Cross Section	A-2
Curb & Gutter	A-3
Typical Sidewalk	A-4
Driveway Detail	A-5
Typical Sidewalk Ramp	A-6
Typical Monument Type 1	A-7
Type III Barricade	A-8
Typical Street & Utility Layout	A-9
Typical Arterial Street & Utility Layout	A-10
Typical Collector Street & Utility Layout	A-11
Typical Neighborhood Street & Utility Layout	A-12
Walking Path	A-13
Shared-Use Path	A-14
HMA Patch Detail	A-15
Typical Precast Drywell Detail	A-16
Catch Basin Type-1	A-17
Catch Basin Type-2	A-18
Typical Trench Detail	A-19
Typical Stop/Street Sign Installation	A-20

WATER

Air & Air-Vacuum Release Assembly	B-1
Double Check Detector Assembly	B-2
Reduced Pressure Backflow Device	B-3

Backflow Prevention Tables	B-4
Meter and Meter Vault Assembly (3" -10")	B-5.1
Meter and Meter Vault Assembly (3"- 10") Specifications	B-5.2
Fire Hydrant Assembly	B-6
1" Water Service W/Mater Setter	B-7
1 ½" – 2" Water Meter Service W/Meter Setter	B-8
Thrust Block Detailed	B-9
Typical Cut-In Connection	B-10
Typical Wet Tap Connection	B-11
Water Sample Station	B-12
Valve Box Adjustment Detail	B-13
Permanent End-Line Blow Off Assembly	B-14
<u>SEWER</u>	
Typical Sewer Manhole	C-1
Side Service	C-2
Drop Manhole Connection	C-3
<u>NON-POTABLE WATER/IRRIGATION</u>	
1" Non-Potable Service Connection	NP-1
Non-Potable Distribution Drain	NP-2

MINIMUM DIMENSIONS

ARTERIALS	COMMERCIAL COLLECTORS	NEIGHBORHOOD COLLECTORS	NEIGHBORHOOD STREET
SIDEWALK (BOTH SIDES)	6 FEET	5 FEET	5 FEET
MIN. STREET WIDTH "L"	58 FEET	48 FEET	40 FEET
ASPHALT DEPTH	4 INCHES	3 INCHES	3 INCHES
CSTC DEPTH	3 INCHES	3 INCHES	3 INCHES
CSBC DEPTH	9 INCHES	6 INCHES	3 INCHES
MIN. RADIUS (FACE OF CURB)	20 FEET	20 FEET	20 FEET
RIGHT OF WAY	80 FEET	70 FEET	66 FEET
CURVATURE (CENTERLINE)	500 FT. RADIUS	300 FT. RADIUS	300 FT. RADIUS
MAXIMUM GRADE	6%	8%	8%

CUL-DE-SACS: MIN. 62 FT. FROM CURB TO CURB, 80 FT. RIGHT-OF-WAY, 6% MAX. GRADE

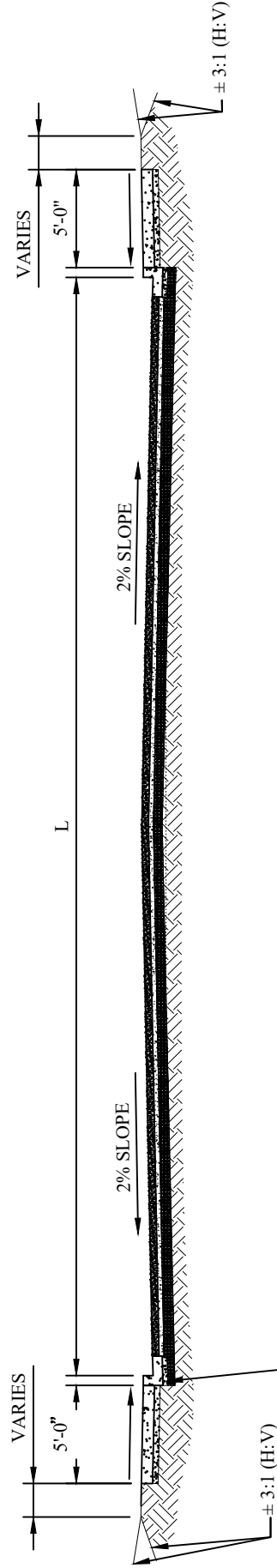

TYPICAL STREET CROSS SECTION

NOTES:

1. STREETS SHALL HAVE A MINIMUM CENTERLINE SLOPE OF 0.5 PERCENT.
2. 95% COMPACTION WILL BE REQUIRED FOR ALL CRUSHED SURFACING (CSTC) MATERIALS.
3. ALL CONSTRUCTION AND MATERIALS SHALL MEET THE CITY OF OTHELLO'S DESIGN STANDARDS AND BE APPROVED BY THE CITY.

CITY OF OTHELLO
STANDARD DETAILS
MINIMUM STREET STANDARDS
DETAIL A-1

#1	November, 2014
#2	June, 2016
#3	February, 2018
#4	March, 2021
REVISION #	DATE



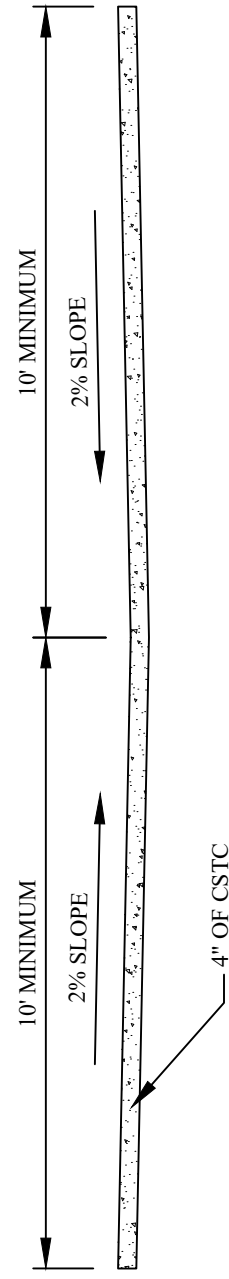
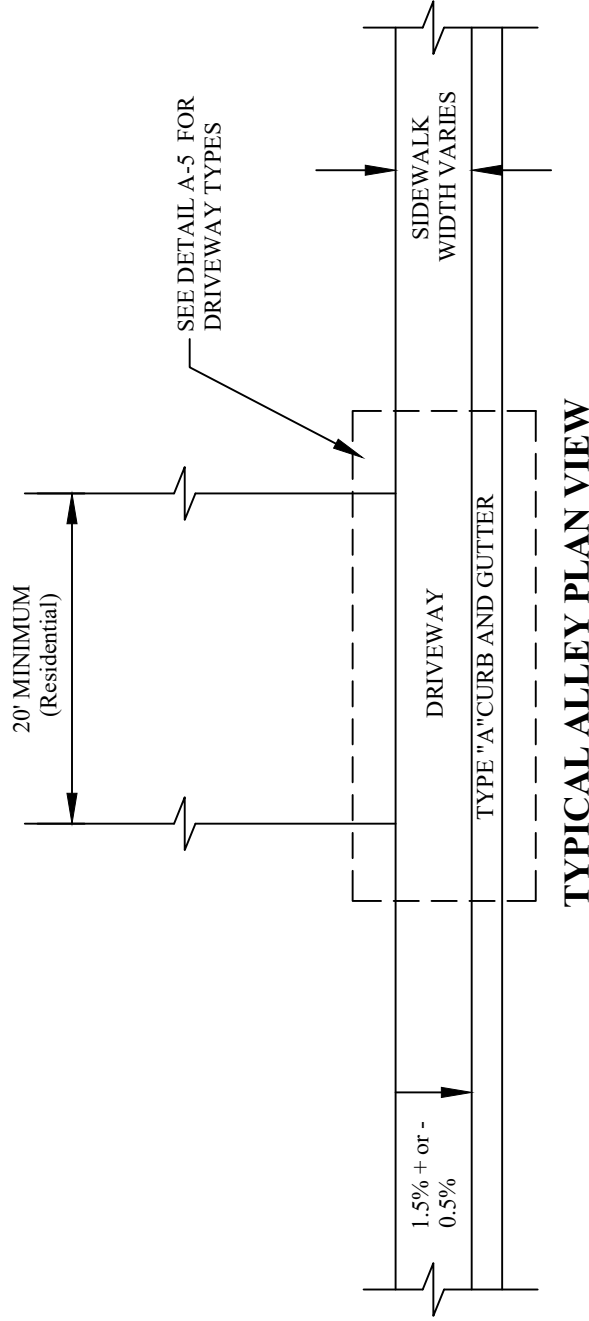

TYPICAL ALLEY CROSS SECTION

NOTES:

1. ALLEYS SHALL BE GRADED AND HAVE 4" CSTC.
2. ALL CONSTRUCTION AND MATERIALS SHALL MEET THE CITY OF OTHELLO'S DESIGN STANDARDS AND BE APPROVED BY THE CITY.

CITY OF OTHELLO
 STANDARD DETAILS
 TYPICAL ALLEY
DETAIL A-2

REVISION #	DATE
#1	November, 2014
#2	June, 2016
#3	March, 2021



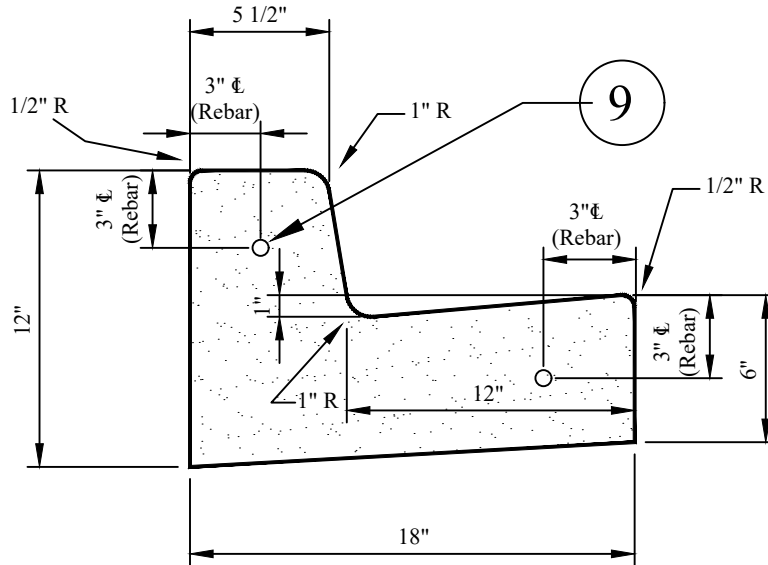

TYPE "A" CURB AND GUTTER CROSS SECTION

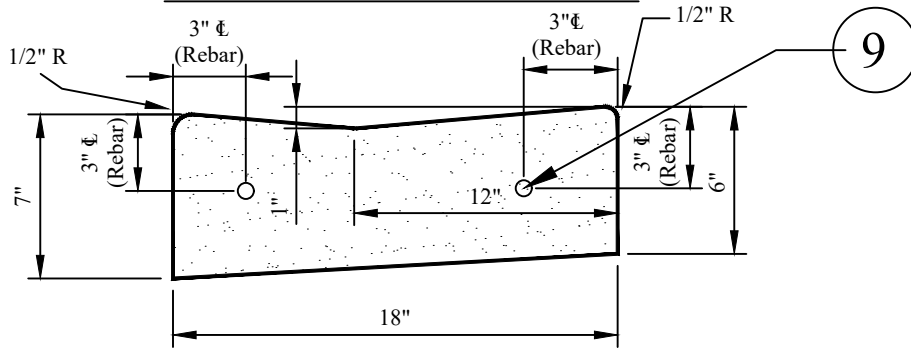

CURB RAMP AND DRIVEWAY CURB CROSS SECTION

TYPICAL CURB AND GUTTER

NOTES:

1. FULL-DEPTH EXPANSION JOINTS SHALL BE PLACED AT 100' INTERVALS AND AT POINTS OF TANGENCY. PREMOLDED JOINT FILLER SHALL BE 3/8" THICK MATERIAL.
2. CONTRACTION JOINTS SHALL BE PLACED AT 10' INTERVALS AND AT BOTH SIDES OF THE GRATE AT CATCH BASINS.
3. 2" OF COMPACTED CRUSHED SURFACING TOP COURSE IS REQUIRED UNDER ALL CONCRETE.
4. THE TOP, FACE, AND GUTTER SHALL BE BROOM FINISHED PARALLEL TO THE ROADWAY.
5. A MINIMUM OF 10' SHALL BE REPLACED WHEN REPLACING PORTIONS OF EXISTING CURB.
6. ALL CONSTRUCTION AND MATERIALS SHALL MEET THE CITY OF OTHELLO'S DESIGN STANDARDS AND BE APPROVED BY THE CITY.
7. STAMP "SS" IN FACE OF CURB AT SEWER SERVICE, "W" FOR WATER, & "IRR" IRRIGATION CROSSING LOCATIONS.
8. A CURING AGENT IS REQUIRED TO BE APPLIED TO ALL EXPOSED SURFACES IMMEDIATELY AFTER BROOMING SURFACE.
9. **2 - 12" #4 REBAR ARE REQUIRED AT ALL CURB CONNECTIONS TO EXISTING CURB. REBAR SHALL PENETRATE EXISTING CURB (6") SIX-INCHES AND EPOXY IN PLACE, WITH NO MASTIC, AS SHOWN ABOVE.**

**CITY OF OTHELLO
STANDARD DETAILS
TYPICAL CURB AND GUTTER
DETAIL A-3**

#1	November, 2014
#2	June, 2016
#3	March, 2021
REVISION #	DATE



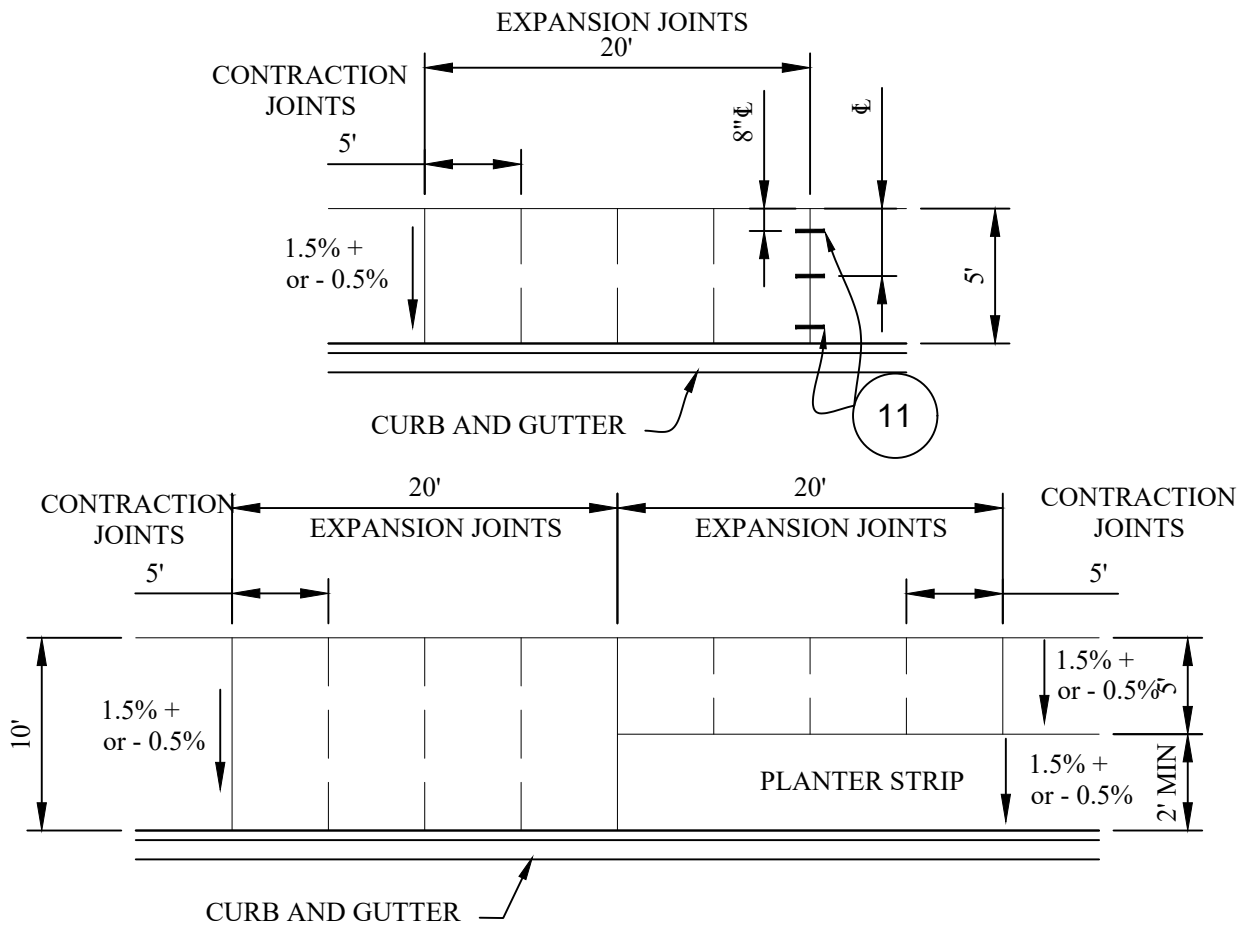

TYPICAL SIDEWALK

NOTES:

1. CONTRACTION JOINTS SHALL BE PLACED PERPENDICULAR TO THE CURB AT 5' INTERVALS.
2. FULL-DEPTH EXPANSION JOINTS SHALL BE PLACED PERPENDICULAR TO THE CURB AT 20' INTERVALS.
3. PRE-MOLDED JOINT FILLER SHALL BE 3/8" THICK MATERIAL AND BE PLACED FULL DEPTH.
4. SIDEWALK AND DRIVEWAYS SHALL BE BROOM FINISHED PERPENDICULAR TO THE CURB.
5. MAINTAIN A MINIMUM OF 5' OF CLEARANCE FOR SIGN, MAILBOX, UTILITY POLE, OR ANY OTHER STRUCTURES WITHIN THE SIDEWALK.
6. 2" OF COMPACTED CRUSHED SURFACING TOP COURSE IS REQUIRED UNDER ALL CONCRETE.
7. MINIMUM SIDEWALK THICKNESS:
4" WHEN BEHIND TYPE "A" CEMENT CONCRETE TRAFFIC CURB AND GUTTER.
6" IN ALL DRIVEWAYS (TOP OF TAPER TO TOP OF TAPER)
8. ALL CONSTRUCTION AND MATERIALS SHALL MEET THE CITY OF OTHELLO'S DESIGN STANDARDS AND BE APPROVED BY THE CITY OF OTHELLO.
9. ALL CONCRETE TO BE CLASS 3,000, PER 8-14.2.
10. A CURING AGENT IS REQUIRED TO BE APPLIED TO ALL EXPOSED SURFACES IMMEDIATELY AFTER BROOMING SURFACE.
11. **(3) THREE - 12" #4 REBAR ARE REQUIRED AT ALL SIDEWALK CONNECTIONS TO EXISTING SIDEWALK. REBAR SHALL PENETRATE EXISTING SIDEWALK (6") SIX-INCHES AND EPOXY IN PLACE, WITH NO MASTIC AT THIS LOCATION. LOCATION OF REBAR IS SHOWN ABOVE.**

D:\STREETS-2020\DETAILS 2021\DETAIL A-4-2021

CITY OF OTHELLO
STANDARD DETAILS
TYPICAL SIDEWALK
DETAIL A-4

#1	November, 2014
#2	June, 2016
#3	February, 2018
#4	March, 2021
REVISION #	DATE



--- CHANGE OF SLOPE
 --- CONTROL JOINTS
 (ON 5' CENTERS)

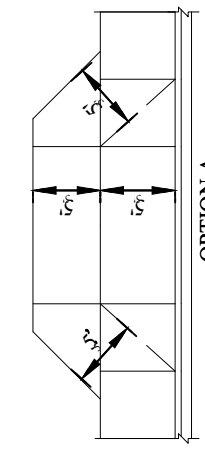

OPTION A

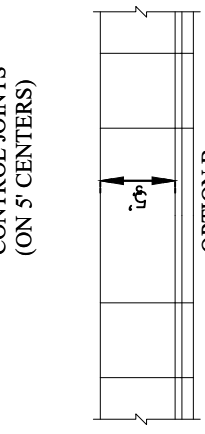

OPTION B

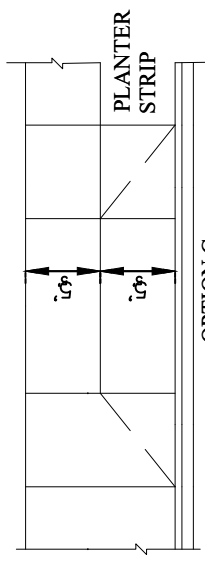

OPTION C

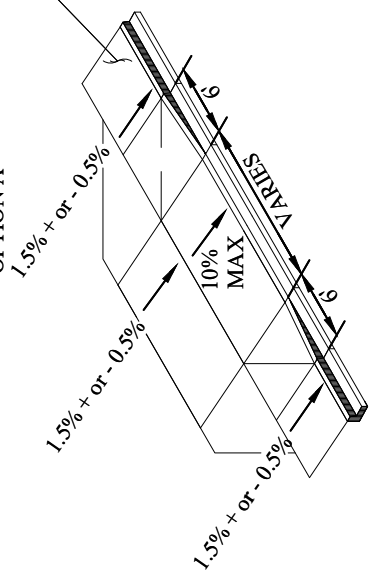

SEE NOTE 11
 (TYP. ALL)

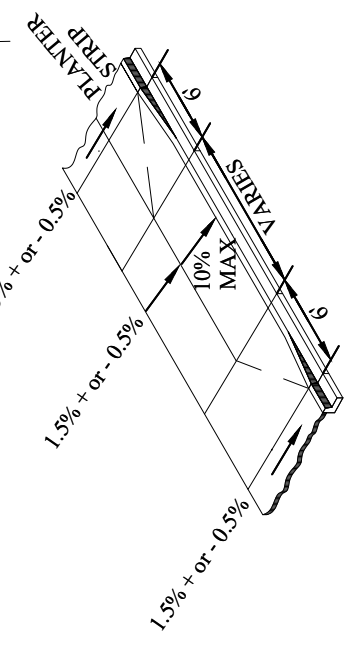
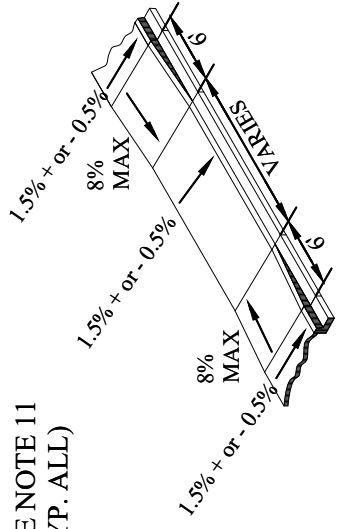

NOTES:

1. ALL JOINTS SHALL BE CLEAN AND EDGED. TRANSVERSE DRIVEWAY JOINTS SHALL BE AS SHOWN OR AS DIRECTED BY THE CITY.
2. 2" OF COMPACTED CRUSHED SURFACING TOP COURSE REQUIRED UNDER ALL CONCRETE.
3. A CURING AGENT IS REQUIRED TO BE APPLIED TO ALL EXPOSED SURFACES IMMEDIATELY AFTER BROOMING SURFACE.
4. MAXIMUM OF ONE DRIVEWAY PERMITTED PER RESIDENCE OR ONE BUSINESS. UNLESS APPROVED IN WRITING BY PUBLIC WORKS DIRECTOR.
5. WHERE DRIVEWAY EXCEEDS 15' IN WIDTH FROM TOP OF TAPER TO TOP OF TAPER A SCRIBED JOINT SHALL BE PLACED ON CENTERLINE OF DRIVEWAY WITH 5' EQUAL SPACING THEREAFTER.
6. CONCRETE SHALL BE 6" THICK IN DRIVEWAY FROM TOP OF TAPER TO TOP OF TAPER.
7. DRIVEWAYS SHALL BE BROOM FINISHED PERPENDICULAR TO THE ROADWAY.
8. THE SETBACKS WILL BE MEASURED FROM THE BACK OF THE EXISTING OR PROJECTED CURB.
9. ALL CONSTRUCTION AND MATERIALS SHALL MEET THE CITY OF OTHELLO'S DESIGN STANDARDS AND BE APPROVED BY THE CITY.
10. WHEN LANDINGS BEHIND DRIVEWAY SLOPES CANNOT BE ACHIEVED, OPTION B SHALL BE USED TO CONFORM WITH ADA REQUIREMENTS.
11. CROSS SLOPES ON ALL SIDEWALKS MUST BE A 1.5% +/- 0.5%.
12. ALL CONCRETE TO BE CLASS 3,000, PER 8-14.2.

DRIVEWAY SEPARATION

BOTTOM OF CURB CUT TAPER MUST BE AT LEAST (6") SIX-FEET FROM PROPERTY CORNER

DRIVEWAY WIDTH

RESIDENTIAL - 10' MIN.
 30' MAX.
 OTHER - AS APPROVED

CITY OF OTHELLO
 STANDARD DETAILS
 DRIVEWAY DETAILS

REVISION #

DATE

#1	November, 2014
#2	June, 2016
#3	March, 2021



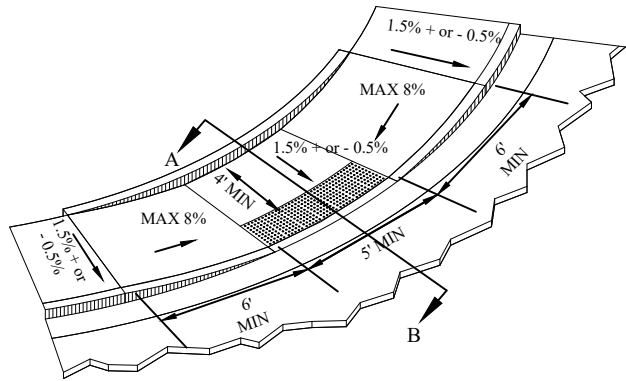
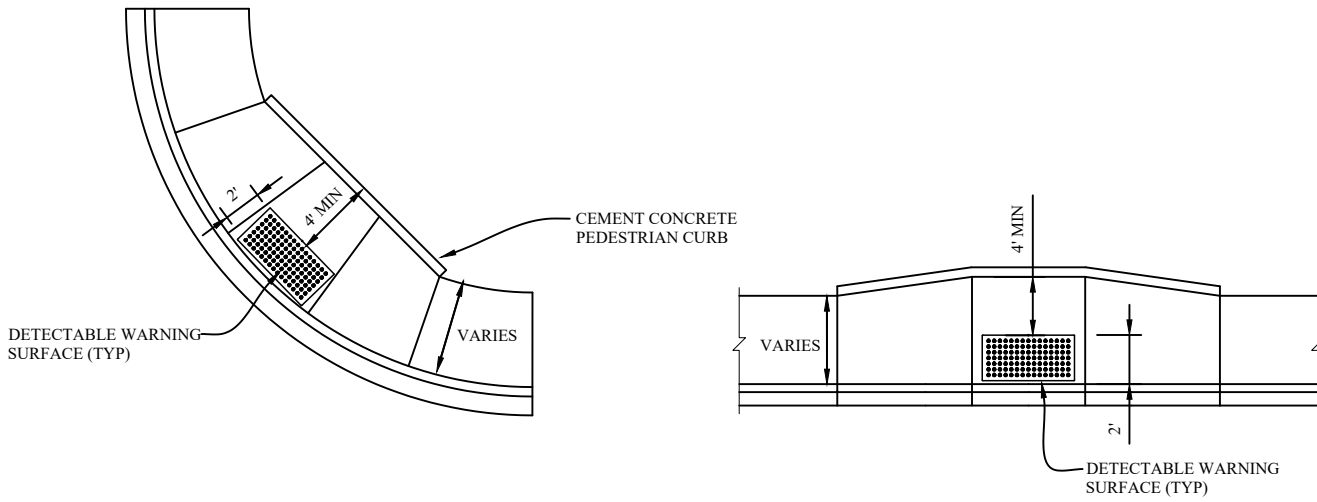

**SIDEWALK RAMP
DETAIL NTS**

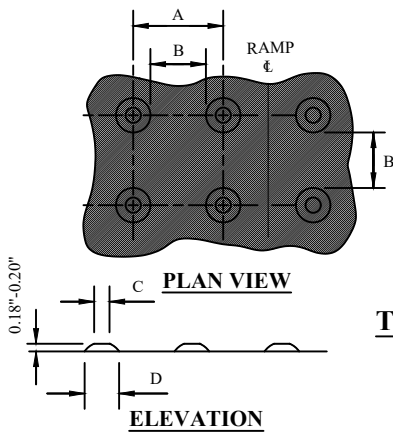

	MIN	MAX
A	1 ⁵ / ₈ "	2 ³ / ₈ "
B	⁵ / ₈ "	1 ¹ / ₂ "
C	⁷ / ₁₆ "	³ / ₄ "
D	⁷ / ₈ "	1 ⁷ / ₁₆ "

**TRUNCATED DOMES
pattern drawing**

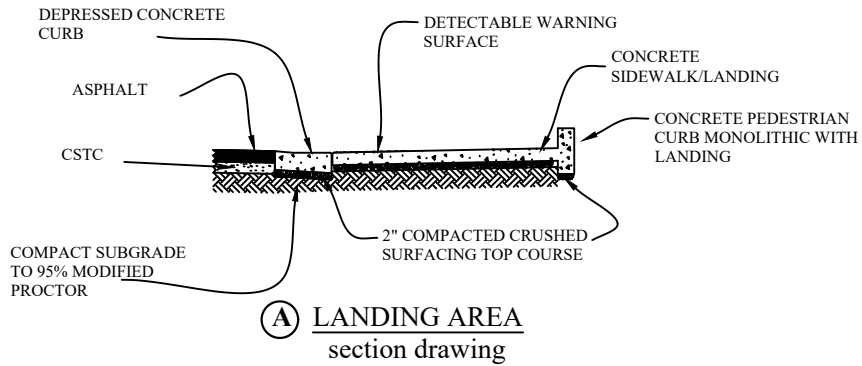

GENERAL NOTES:

- SEE DETAIL A-4 FOR CONSTRUCTION OF DEPRESSED CONCRETE CURB AND GUTTER FOR RAMPS.
- SEE DETAIL A-3 FOR CONSTRUCTION OF CONCRETE SIDEWALK.
- SIDEWALK RAMP SHALL BE A MINIMUM OF 4" THICK.
- SIDEWALK RAMP SHALL BE BROOM FINISHED PERPENDICULAR TO BACK OF CURB.
- SIDEWALK RAMP SLOPES SHALL BE A MAXIMUM OF 8% (12H:1V).
- DETECTABLE WARNING SURFACE SHALL BE CONSTRUCTED OF CAST-IN-PLACE INLINE DOME TACTILE TILE MODULES. THE PATTERN OF THE DOMES SHALL CONFORM TO THE DIMENSIONS SHOWN ON THIS DETAIL.
- DETECTABLE WARNING SURFACE SHALL BE YELLOW IN COLOR. THE COLOR SHALL BE AN INTEGRAL PART OF THE MATERIAL AND SHALL NOT BE SURFACE APPLIED.
- ALL CONSTRUCTION AND MATERIALS SHALL MEET THE CITY OF OTHELLO'S DESIGN STANDARDS AND BE APPROVED BY THE CITY.
- RAMP RUNNING SLOPES SHALL BE 8% MAXIMUM (THE RAMP LENGTH IS NOT REQUIRED TO EXCEED 15 FEET ALONG THE SIDEWALK)
- CROSS SLOPES ON ALL SIDEWALKS MUST BE A MINIMUM OF 1% AND A MAXIMUM OF 2%.

CITY OF OTHELLO
STANDARD DETAILS
TYPICAL SIDEWALK RAMP
DETAIL A-6

#1	November, 2014
#2	June, 2016
#3	February, 2018
#4	March, 2021
REVISION #	DATE



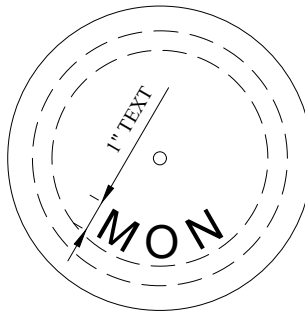

**PLAN VIEW
COVER**

1.5" COMPACTED CL 3/8" PG 64-28
HOT MIX ASPHALT

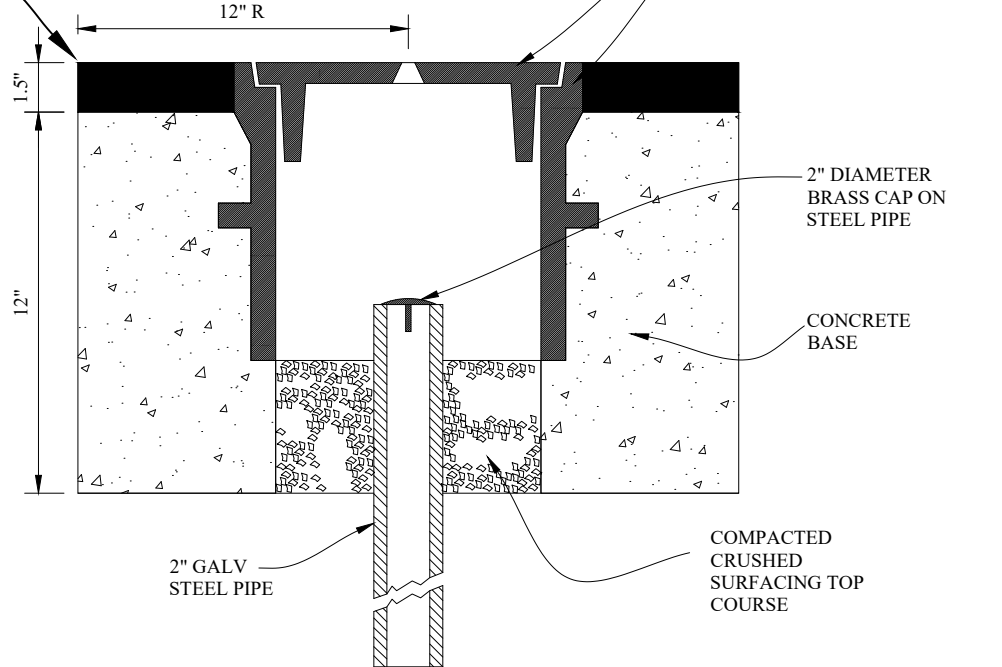

SECTION

MONUMENT CASE AND COVER

NOTES:

1. BRASS CAP SHALL BE A MINIMUM OF 2" IN DIAMETER.
2. AREA EXCAVATED TO INSTALL MONUMENT SHALL BE BACKFILLED WITH CSTC TO WITHIN 9" OF FINISHED GRADE (OF THE MONUMENT CASE) AND COMPACTED TO 95% OF MAXIMUM DENSITY. THE VOID INSIDE THE MONUMENT CASE SHALL ALSO BE FILLED WITH CSTC TO WITHIN 2" OF THE BOTTOM OF THE BRASS CAP.
3. ADJUST MONUMENT IN ASPHALT TO 1/4" BELOW FINISHED GRADE.
4. "MON" SHALL BE CAST INTO THE LID.
5. ALL CONSTRUCTION AND MATERIALS SHALL MEET THE CITY OF OTHELLO'S DESIGN STANDARDS AND BE APPROVED BY THE CITY.

#1	November, 2014
#2	June, 2016
#3	March, 2021
REVISION #	DATE



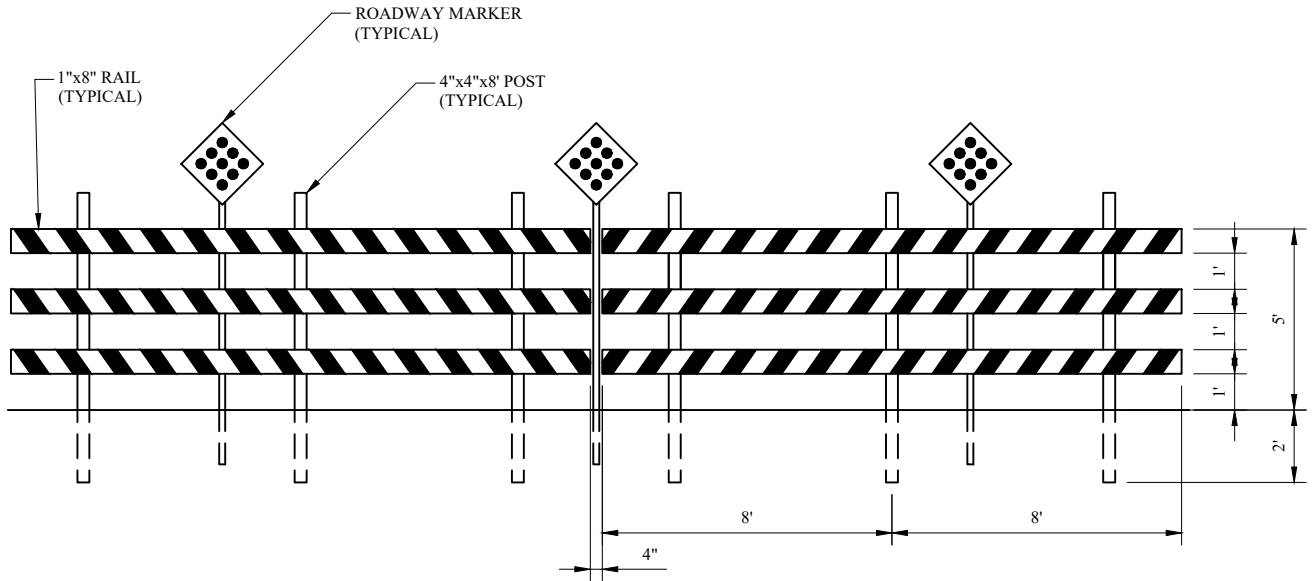

TYPE III - BARRICADE FOR TEMPORARY NO-OUTLET STREET

NOTES:

1. END-OF-ROADWAY MARKER SHALL BE PER THE MANUAL ON UNIFORM TRAFFIC CONTROL DEVICES, SECTION 6F.68, RETROREFLECTIVE WHITE AND RETROREFLECTIVE RED.
2. ROADWAY MARKER POSTS TO BE 2" O.D. GALVANIZED PERFERATED SIGN POSTS AND SLEEVES BEHIND BARRICADES.
3. 4"x4"x8' POSTS SHALL BE PRESSURE TREATED LUMBER, PRIMED AND PAINTED WHITE.
4. RAILS SHALL BE PLASTIC, 1" THICK BY 8" WIDE, RED ON WHITE, WITH REFLECTIVE STRIPES FACTORY APPLIED.
5. LENGTH OF BARRICADE SHALL BE OF A LENGTH THAT WILL PHYSICALLY RESTRICT ACCESS BY MOTORIZED VEHICLES.
6. BARRICADES SHALL MEET THE REQUIREMENTS OF SECTIONS 2B.67 AND 6F.68 OF THE MANUAL ON UNIFORM TRAFFIC CONTROL DEVICES.
7. ALL CONSTRUCTION AND MATERIALS SHALL MEET THE CITY OF OTHELLO'S DESIGN STANDARDS AND BE APPROVED BY THE CITY ENGINEER.

**TO BE USED ONLY AS REQUIRED
OR APPROVED BY PUBLIC WORKS DIRECTOR**

#1	November, 2014
#2	June, 2016
#3	March, 2021
REVISION #	DATE



Road Width Varies

(See Detail-A-1)

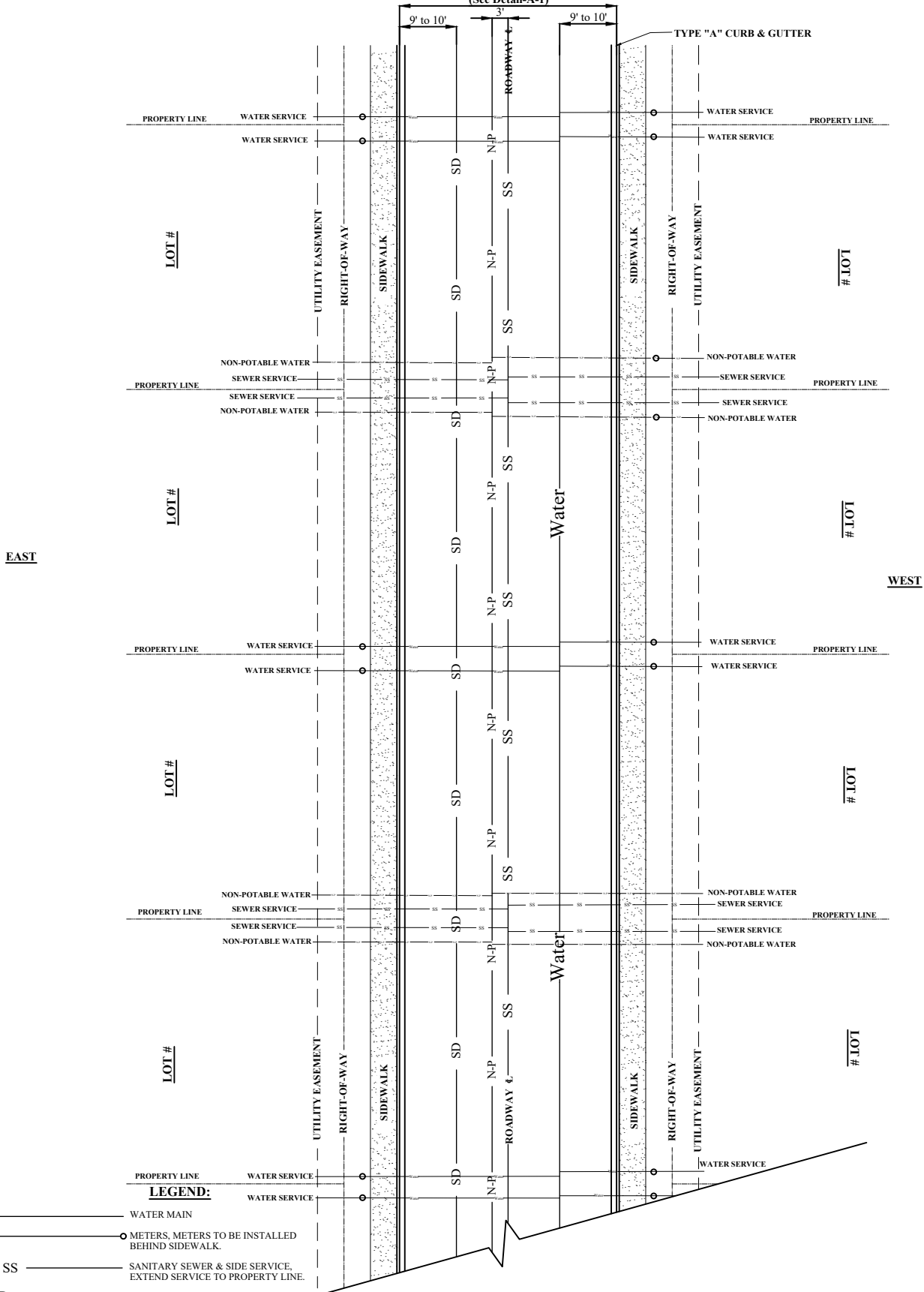

- LEGEND:**
- WATER MAIN
 - METERS, METERS TO BE INSTALLED BEHIND SIDEWALK.
 - SS — SANITARY SEWER & SIDE SERVICE, EXTEND SERVICE TO PROPERTY LINE.
 - SD — STORM DRAIN MAIN.
 - N-P — NON-POTABLE WATER.
 - RIGHT-OF-WAY.
 - - - UTILITY EASEMENT.

CITY OF OTHELLO
 STANDARD DETAILS
 TYPICAL STREET & UTILITY LAYOUT
DETAIL A-9

#1	November, 2014
#2	June, 2016
#3	February, 2020
#4	March, 2021
REVISION #	DATE



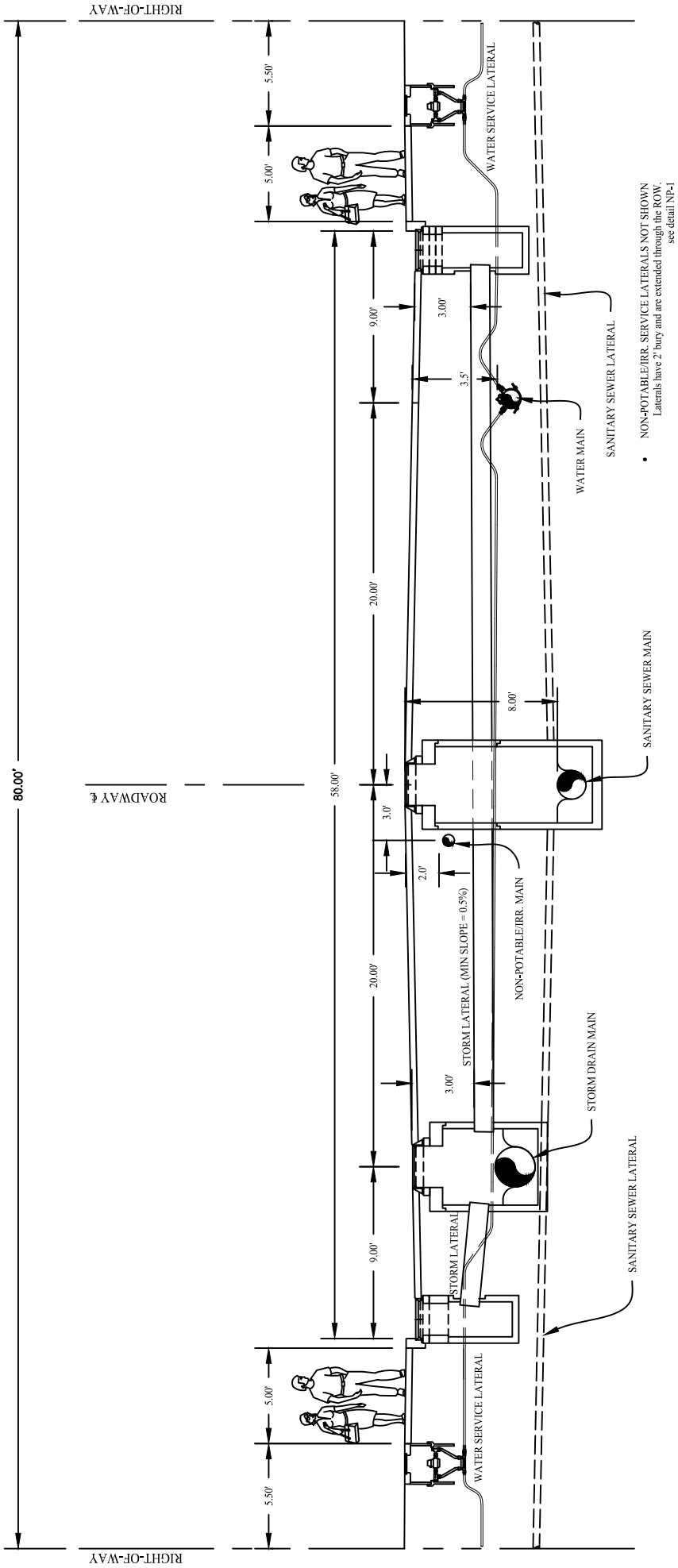

TYPICAL ROAD SECTION - ARTERIAL STREET

GENERAL NOTES:

1. ACCORDING TO THE PIPELINE SEPARATION DESIGN AND INSTALLATION REFERENCE GUIDE (PUBLICATION NUMBER 06-10-029)
- WHEN THE NON-POTABLE PIPELINE MUST CROSS ABOVE THE POTABLE PIPELINE, ONE OR BOTH OF THE PIPELINES SHALL BE ENCASED WITH PRESSURE RATED CASING PIPE OR CONTROLLED DENSITY FILL (CDF) AT LEAST 10 FT ON EITHER SIDE OF THE CROSSING.
- THE MINIMUM VERTICAL SEPARATION BETWEEN POTABLE PIPELINE CROSSING OVER NON-POTABLE PIPELINE SHALL BE 18". IF 18" OF SEPARATION IS NON-ATTAINABLE THEN ONE OR BOTH OF THE PIPELINES SHALL BE ENCASED WITH PRESSURE RATED CASING PIPE OR CONTROLLED DENSITY FILL (CDF) AT LEAST 10 FT ON EITHER SIDE OF THE CROSSING.
2. SEE STANDARD DETAIL(S) "FIGURE W5-SHEET 1" AND/OR "FIGURE W5-SHEET 2" FOR THE WATER METER SERVICE, SETTER, AND METER BOX LAYOUT, MATERIALS, AND BURY DEPTHS.
3. ALL STORM DRAIN LATERALS BURIED SHALLOWER THAN 3 FT. MUST BE H-20 TRAFFIC RATED.
4. INSTALL BACKFLOW DEVICE WITHIN 3-5 FEET OF WATER SERVICE.

• NON-POTABLE/IRR. SERVICE LATERALS NOT SHOWN
Laterals have 2' bury and are extended through the ROW.
see detail NP-1

		#1	November, 2014
		#2	June, 2016
		#3	February, 2018
		#4	March, 2021
		REVISION #	DATE

CITY OF OTHELLO
 STANDARD DETAILS
 TYPICAL ARTERIAL STREET UTILITY LAYOUT
DETAIL A-10



#1	November, 2014
#2	June, 2016
#3	February, 2018
#4	January, 2021
REVISION #	DATE

CITY OF OTHELLO
 STANDARD DETAILS
 TYPICAL COLLECTOR STREET UTILITY LAYOUT
DETAIL A-11

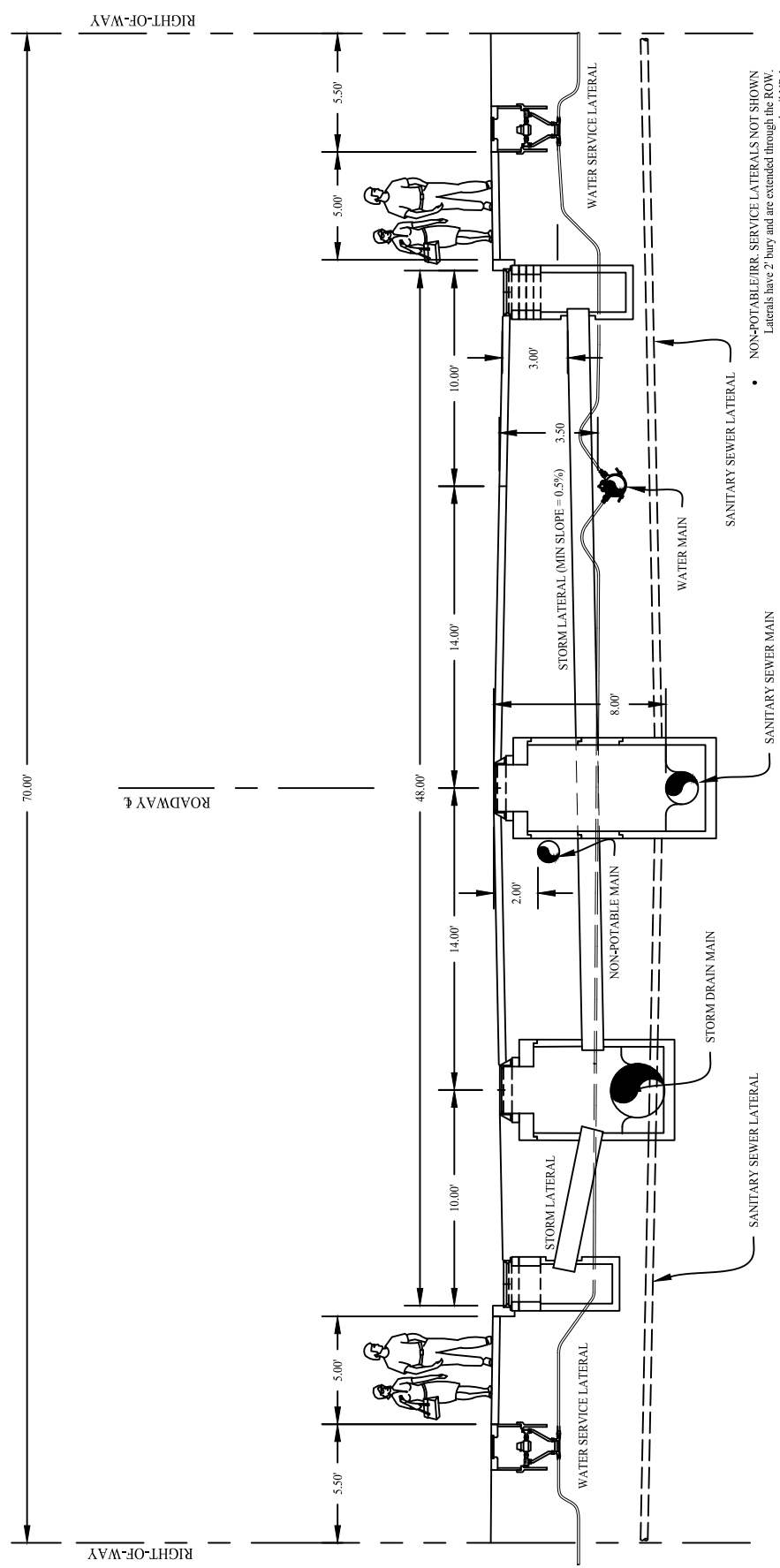

TYPICAL ROAD SECTION - COMMERCIAL & NEIGHBORHOOD COLLECTOR

GENERAL NOTES:

1. ACCORDING TO THE PIPELINE SEPARATION DESIGN AND INSTALLATION REFERENCE GUIDE (PUBLICATION NUMBER 06-10-029)
- WHEN THE NON-POTABLE PIPELINE MUST CROSS ABOVE THE POTABLE PIPELINE, ONE OR BOTH OF THE PIPELINES SHALL BE ENCASED WITH PRESSURE RATED CASING PIPE OR CONTROLLED DENSITY FILL (CDF) AT LEAST 10 FT ON EITHER SIDE OF THE CROSSING.
- THE MINIMUM VERTICAL SEPARATION BETWEEN POTABLE PIPELINE CROSSING OVER NON-POTABLE PIPELINE SHALL BE 18". IF 18" OF SEPARATION IS NON-ATTAINABLE THEN ONE OR BOTH OF THE PIPELINES SHALL BE ENCASED WITH PRESSURE RATED CASING PIPE OR CONTROLLED DENSITY FILL (CDF) AT LEAST 10 FT ON EITHER SIDE OF THE CROSSING.
2. SEE STANDARD DETAIL(S) "FIGURE W-5-SHEET 1" AND/OR "FIGURE W-5-SHEET 2" FOR THE WATER METER SERVICE, SETTER, AND METER BOX LAYOUT, MATERIALS, AND BURY DEPTHS.
3. ALL STORM DRAIN LATERALS BURIED SHALLOWER THAN 3 FT. MUST BE H-20 TRAFFIC RATED.
4. INSTALL BACKFLOW DEVICE WITHIN 3-5 FEET OF WATER SERVICE.



REVISION #	DATE
#1	November, 2014
#2	June, 2016
#3	February, 2018
#4	March, 2021

CITY OF OTHELLO
 STANDARD DETAILS
 TYPICAL NEIGHBORHOOD STREET UTILITY
 LAYOUT
DETAIL A-12

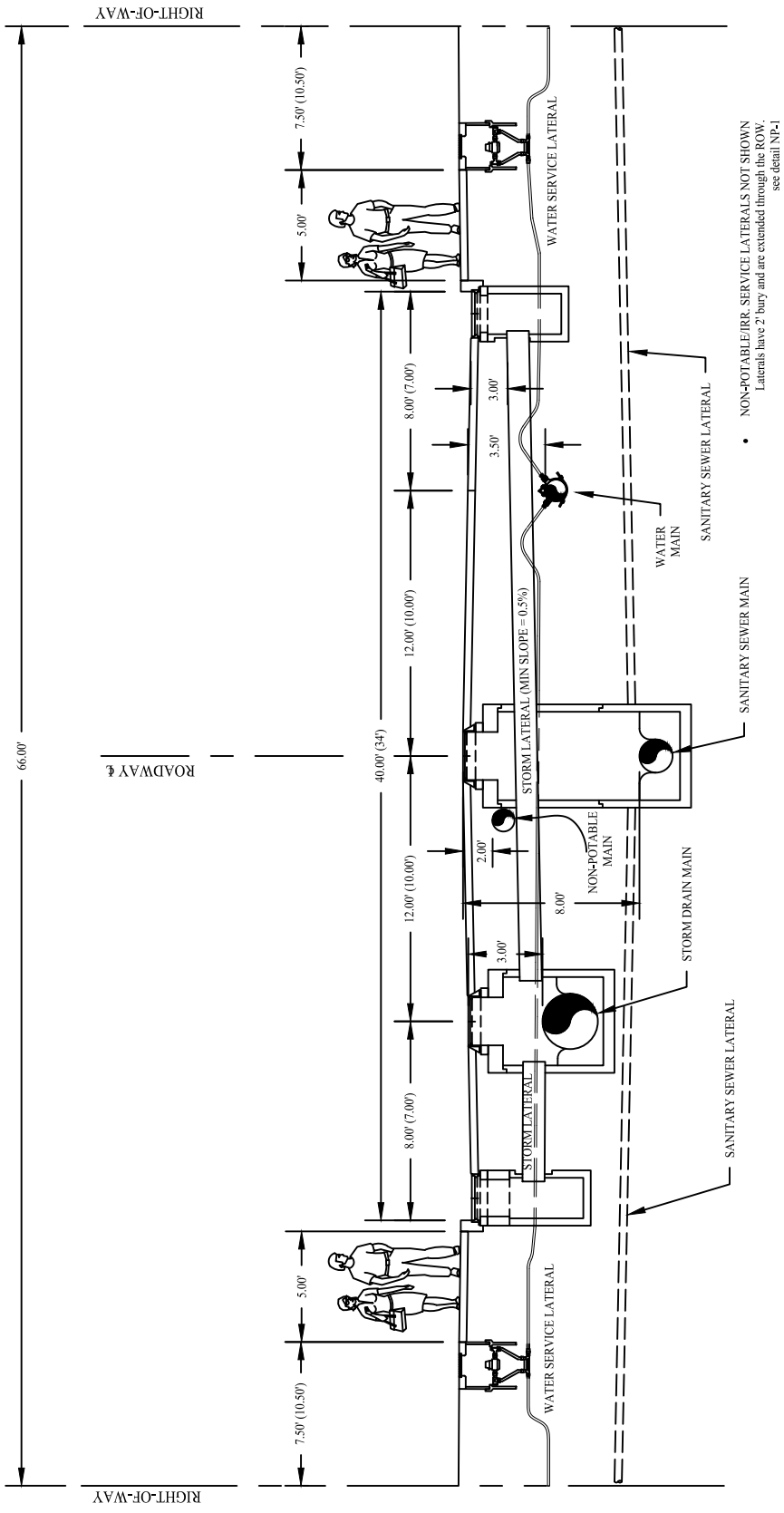

TYPICAL ROAD SECTION - NEIGHBORHOOD STREET

GENERAL NOTES:

1. ACCORDING TO THE PIPELINE SEPARATION DESIGN AND INSTALLATION REFERENCE GUIDE (PUBLICATION NUMBER 06-10-029)
- WHEN THE NON-POTABLE PIPELINE MUST CROSS ABOVE THE POTABLE PIPELINE, ONE OR BOTH OF THE PIPELINES SHALL BE ENCASED WITH PRESSURE RATED CASING PIPE OR CONTROLLED DENSITY FILL (CDF) AT LEAST 10 FT ON EITHER SIDE OF THE CROSSING.
- THE MINIMUM VERTICAL SEPARATION BETWEEN POTABLE PIPELINE CROSSING OVER NON-POTABLE PIPELINE SHALL BE 18" IF 18" OF SEPARATION IS NON-ATTAINABLE THEN ONE OR BOTH OF THE PIPELINES SHALL BE ENCASED WITH PRESSURE RATED CASING PIPE OR CONTROLLED DENSITY FILL (CDF) AT LEAST 10 FT ON EITHER SIDE OF THE CROSSING.
2. SEE STANDARD DETAIL(S) "FIGURE W5-SHEET 1" AND/ OR "FIGURE W5-SHEET 2" FOR THE WATER METER SERVICE, SETTER, AND METER BOX LAYOUT, MATERIALS, AND BURY DEPTHS.
3. ALL STORM DRAIN LATERALS BURIED SHALLower THAN 3 FT. MUST BE H-20 TRAFFIC RATED.
4. INSTALL BACKFLOW DEVICE WITHIN 3-5 FEET OF WATER SERVICE.

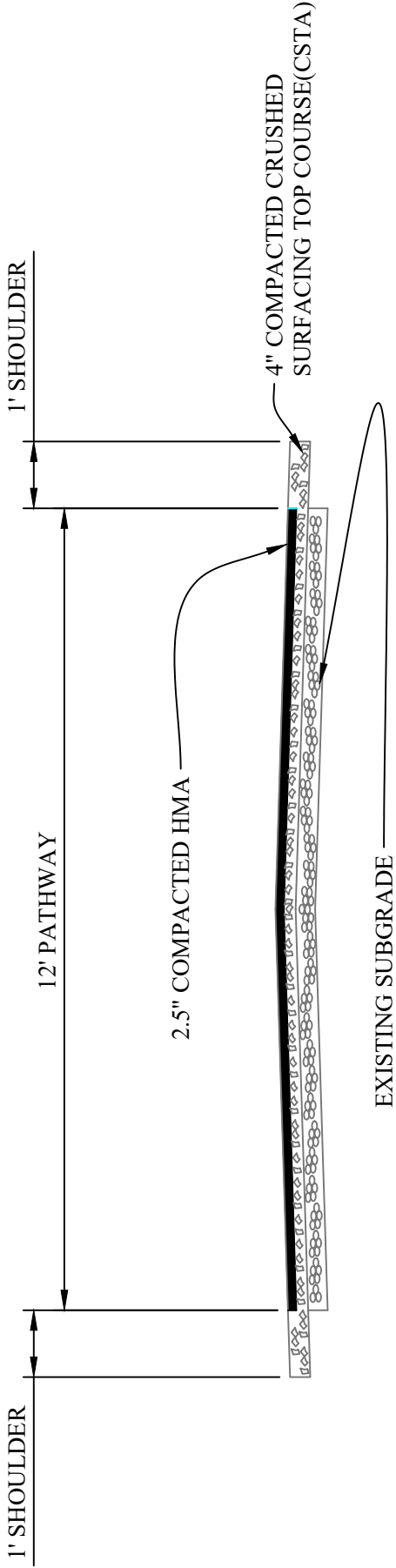

WALKING PATH

NTS

CITY OF OTHELLO
STANDARD DETAILS
TYPICAL WALKING PATH
DETAIL A-13

REVISION #	DATE
#1	November, 2014
#2	June, 2016
#3	February, 2018
#4	March, 2021



3' MINIMUM
SEPARATION
FROM
ROADWAYS

2' CLEAR SPACE
ON BOTH SIDES

14' PATHWAY

2" COMPACTED HMA

GRASS OR LOW
GROUND COVERS

GRASS OR LOW
GROUND COVERS

4" CSTC at 95%
COMPACTION

EXISTING SUBGRADE

SHARED-USE PATH

NTS

NOTES:

1. Maximum cross slopes shall be 1.8%.
2. Cross slopes of shoulders can be no steeper than 6H:1V
3. Path shall meet Design Manual 1515 Shared-Use Paths - WSDOT and the American Association of State Highway and Transportation Officials' (AASHTO) design guidelines.

CITY OF OTHELLO
STANDARD DETAILS
TYPICAL SHARED-USE PATH
DETAIL A-14

REVISION #	DATE



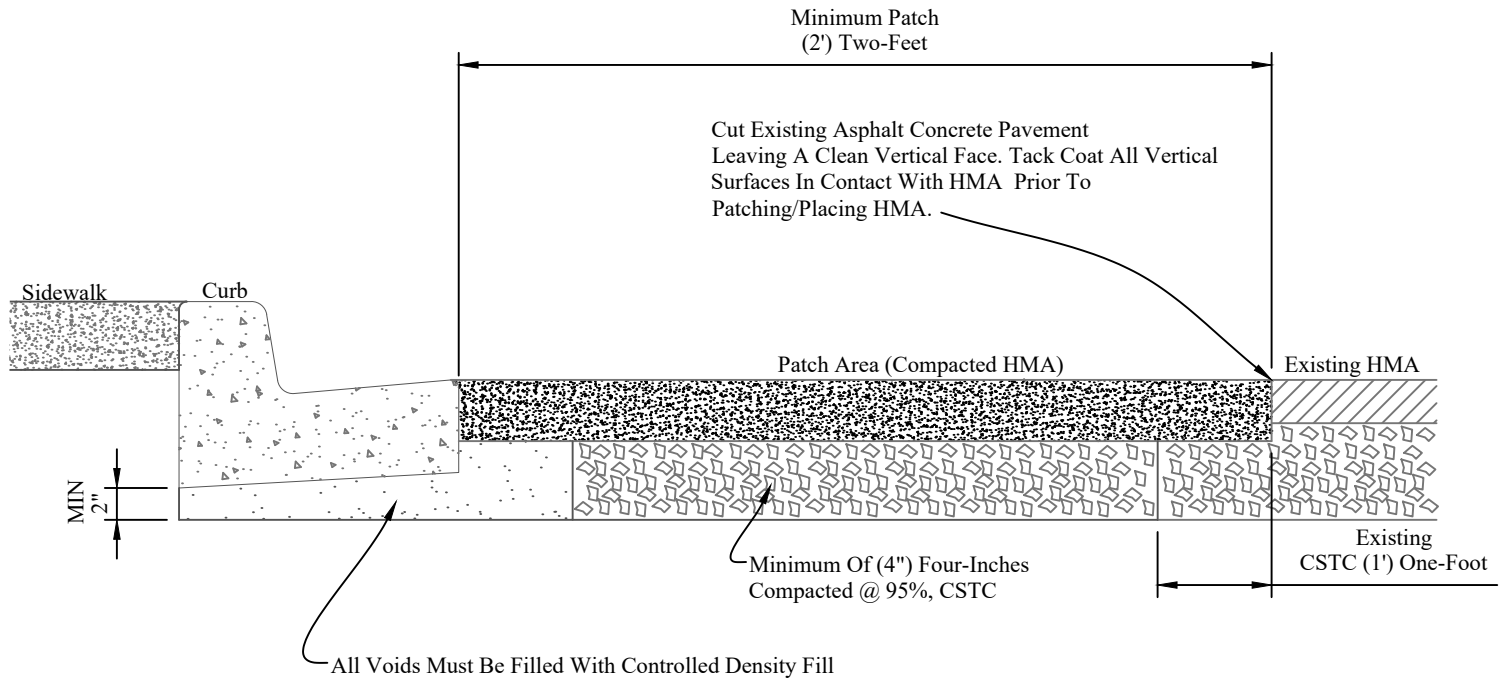

PATCHING DETAIL
NTS

NOTES:

1. HOT MIX ASPHALT (HMA) IN THE PATCH ZONE SHALL BE CL 3/8". MINIMUM THICKNESS SHALL BE 3", OR MATCH EXISTING, WHICHEVER IS GREATER. ALL PATCHES SHALL BE PLACED IN A MINIMUM OF 2 LIFTS. MAXIMUM DEPTH OF LIFTS SHALL BE 3" COMPACTED.
2. PATCH WIDTH MUST ACCOMMODATE PROPER COMPACTION METHODS AS APPROVED BY THE CITY.
4. ALL CONSTRUCTION AND MATERIALS SHALL MEET THE CITY OF OTHELLO'S DESIGN STANDARDS AND BE APPROVED BY THE CITY.

#1	November, 2014
#2	June, 2016
#3	March, 2021
REVISION #	DATE



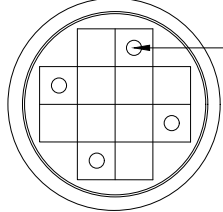
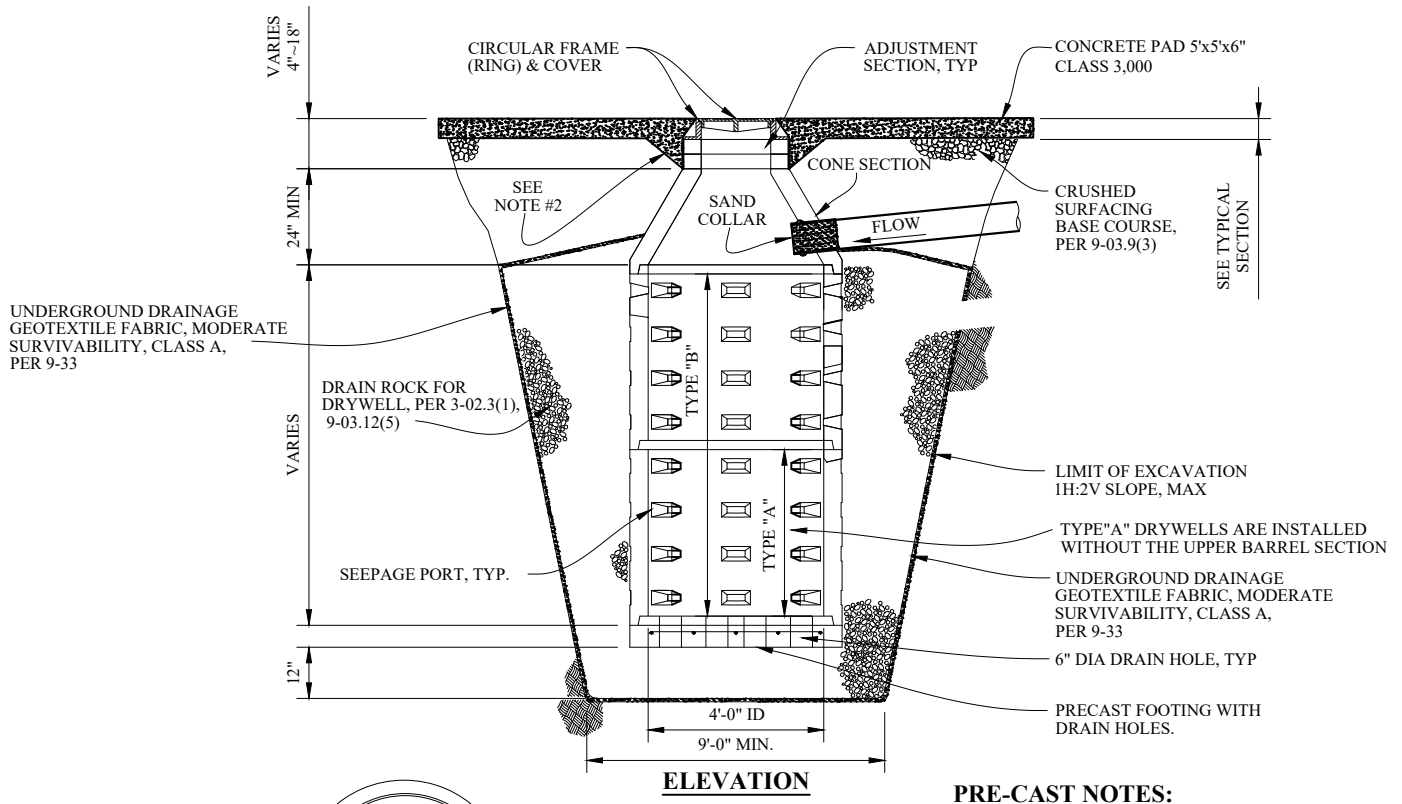

PRECAST FOOTING DETAIL

PRE-CAST NOTES:

1. SEEPAGE PORT ORIENTATION VARIES AMONG MANUFACTURERS.
2. CONNECT INLET PIPE TO STRUCTURE USING PRECAST HOLE OR CORE DRILLED HOLE.
3. FOR DEPTHS OVER 15' USE 72" X 8" ALTERNATIVE PRECAST FOOTING.

48" PRECAST CONCRETE DRYWELL

NOTES:

1. MINIMUM OF 1 (one) 4" ADJUSTMENT RING WITH A MAXIMUM OF 16" OF ADJUSTMENT.
2. PLACE CONCRETE AROUND OUTSIDE OF ADJUSTMENT RINGS AND RING TO PREVENT INFILTRATION/EXFILTRATION.
3. PRECAST CONE SECTION MAY BE CONCENTRIC OR ECCENTRIC.
4. GROUT SEAL PVC SAND COLLAR WHERE THE PIPE PENETRATES THE DRYWELL INSIDE AND OUTSIDE.
5. DRYWELLS NOT IN SIDEWALK SHALL BE PLACED IN A 6'x6' CONCRETE PAD AT FINISHED GRADE.
6. "DRAIN" AND "CITY OF OTHELLO" SHALL BE CAST IN THE LID. FRAMES SHALL BE MODEL A-2000-R-1 BY D&L FOUNDRY AND COVERS SHALL BE MODEL A-2000-25 BY D&L FOUNDRY.
7. ALL CONSTRUCTION AND MATERIALS SHALL MEET THE CITY OF OTHELLO'S DESIGN STANDARDS AND BE APPROVED BY THE CITY ENGINEER.

D:\STREETS-2020\DETAILS 2021\DETAIL A-16-2021

CITY OF OTHELLO
STANDARD DETAILS
48" PRECAST CONCRETE DRYWELL
DETAIL A-16

REVISION #	DATE



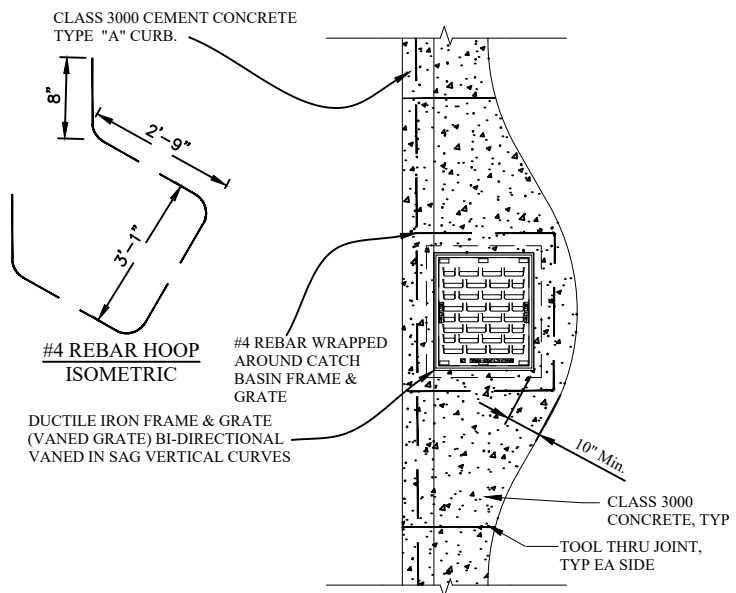

PLAN VIEW

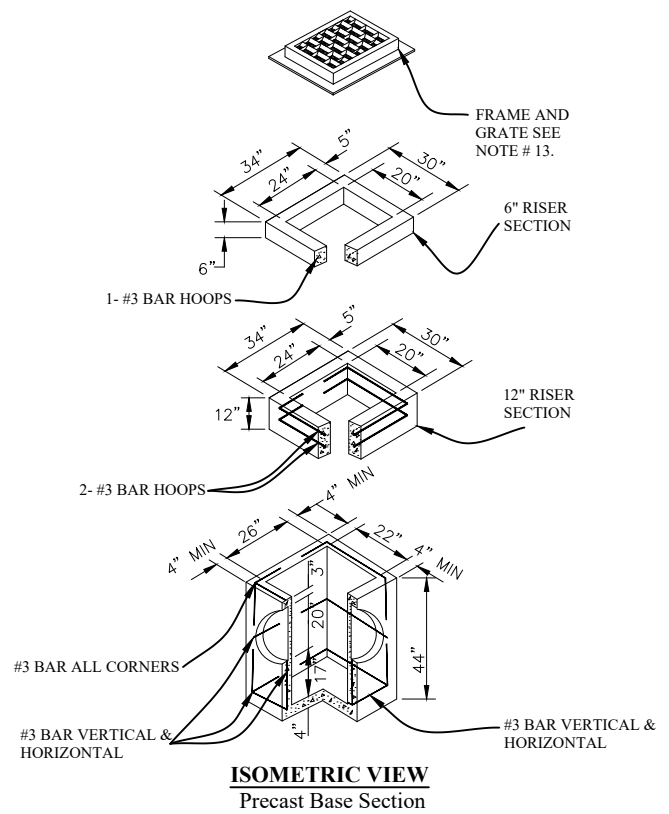

ISOMETRIC VIEW
Precast Base Section

NOTES:

1. CATCH BASINS SHALL BE CONSTRUCTED IN ACCORDANCE WITH SECTION 9-05.50(1) WSDOT/APWA STANDARD SPECIFICATIONS, EXCEPT THAT THE DIMENSIONS SHALL BE IN ACCORDANCE WITH DETAIL.
2. ALL REINFORCED CAST-IN-PLACE CONCRETE SHALL BE CLASS 4000.
3. PRECAST BASES SHALL BE FURNISHED WITH CUTOUTS OR KNOCKOUTS. KNOCKOUTS SHALL HAVE A WALL THICKNESS OF 2" MIN. ALL PIPE SHALL BE INSTALLED IN FACTORY PROVIDED KNOCKOUTS. UNUSED KNOCKOUTS NEED NOT BE GROUTED IF WALL IS LEFT INTACT.
4. KNOCKOUT OR CUTOUT HOLE SIZE IS EQUAL TO PIPE OUTER DIAMETER PLUS CATCH BASIN WALL THICKNESS.
5. ROUND KNOCKOUTS MAY BE ON ALL 4 SIDES, WITH MAX. DIAMETER OF 20". KNOCKOUTS MAY BE EITHER ROUND OR "D" SHAPE.
6. THE MAX. DEPTH FROM THE FINISHED GRADE TO THE PIPE INVERT IS 5'-0".
7. THE TAPER ON THE SIDES OF THE PRECAST BASE SECTION AND RISER SECTION SHALL NOT EXCEED 1/2"/FT.
8. CATCH BASIN FRAME AND GRATE SHALL BE DUCTILE IRON (ASTM A536 GRADE 80-55-06) IN ACCORDANCE WITH STANDARD SPECIFICATIONS AND MEET THE STRENGTH REQUIREMENTS OF FEDERAL SPECIFICATION RR-F-62ID.
9. FOR CATCH BASINS IN PARKING LOTS REFER TO WSDOT/APWA STANDARD PLAN 8-5.60-01.
10. EDGE OF RISER SHALL NOT BE OFFSET MORE THAN 2" FROM VERTICAL EDGE OF CATCH BASIN WALL.
11. FRAME AND GRATE SHALL BE VANED TYPE DUCTILE IRON ASTM A536 GRADE 80-55-06 WITH "OUTFALL TO STREAM DUMP NO POLLUTANTS" AND "CITY OF OTHELLO" IN RAISED LETTERS.
12. CATCH BASINS ARE TO BE POURED CONTIGUOUS WHEN CURB IS PLACED. WHEN CATCH BASINS ARE POURED AFTER CURB PLACEMENT, THREE (3)- #4 REBAR 16" IN LENGTH SHALL BE INSTALL AS PINS ON EACH CONNECTING ENDS.
13. D & L Foundry I-4432.02 (with vaned grate)
D & L Foundry I-4432.03 (with bi-directional vaned grate)
(or approved equal)

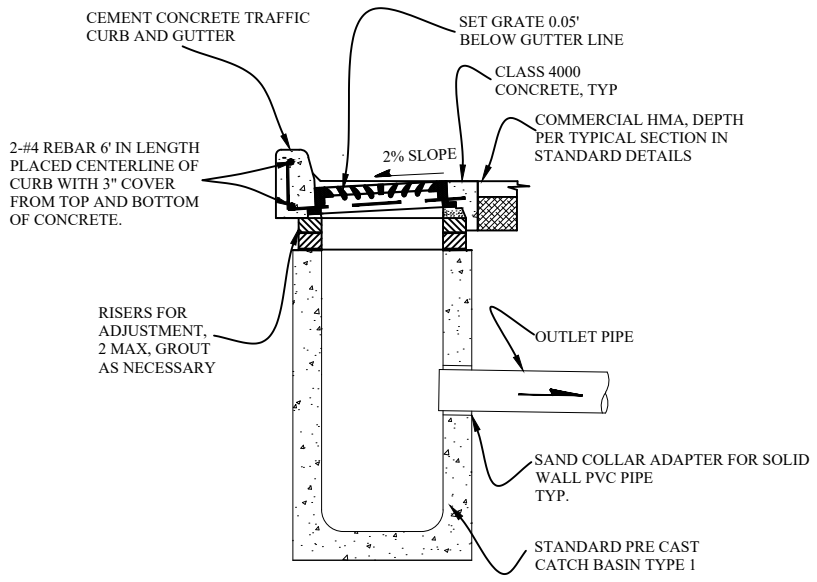

SECTION

CATCH BASIN TYPE 1
NTS

D:\STREETS-2020\DETAILS 2021\DETAIL A-17-2021

CITY OF OTHELLO
STANDARD DETAILS
CATCH BASIN - TYPE 1
DETAIL A-17

#1	November, 2014
#2	June, 2016
#3	March, 2021
REVISION #	DATE



NOTES:

1. CATCH BASINS SHALL BE CONSTRUCTED IN ACCORDANCE WITH ASTM C478 (AASHTO M199) AND ASTM C890 UNLESS OTHERWISE SHOWN ON PLANS OR NOTED IN THE STANDARD SPECIFICATIONS.
2. HANDHOLDS IN ADJUSTMENT SECTION SHALL HAVE 3" MIN. CLEARANCE. STEPS IN CATCH BASIN SHALL HAVE 6" MIN. CLEARANCE. HANDHOLDS SHALL BE PLACED IN ALTERNATING GRADE RINGS OR LEVELING COURSE WITH A MIN. OF ONE HANDHOLD BETWEEN THE LAST STEP AND TOP TO THE FINISHED GRADE. ALL STEPS AND HANDHOLDS SHALL BE MADE OF POLY PROPYLENE.
3. ALL REINFORCED CAST-IN-PLACE CONCRETE SHALL BE CLASS 4000. ALL PRECAST CONCRETE SHALL BE CLASS 4000.

4. PRECAST BASES SHALL BE FURNISHED WITH CUTOUTS OR KNOCKOUTS. KNOCKOUTS SHALL HAVE WALL THICKNESS OF 2" MIN. UNUSED KNOCKOUTS NEED TO BE GROUTED INSIDE AND OUT. PIPES SHALL BE INSTALLED ONLY IN FACTORY KNOCKOUTS UNLESS OTHERWISE APPROVED BY THE ENGINEER.
5. KNOCKOUT OR CUTOUT HOLE SIZE SHALL EQUAL PIPE OUTER DIAM. PLUS CATCH BASIN WALL THICKNESS. MAX. HOLE SIZE SHALL BE 36" FOR 48" CATCH BASIN, 42" FOR 54" C.B., 48" FOR 60" C.B., 60" FOR 72" C.B., 84" FOR 96" C.B. MIN. DISTANCE BETWEEN HOLES SHALL BE 8" FOR 48", 54", AND 60" C.B.; 12" FOR 72" AND 96" C.B.

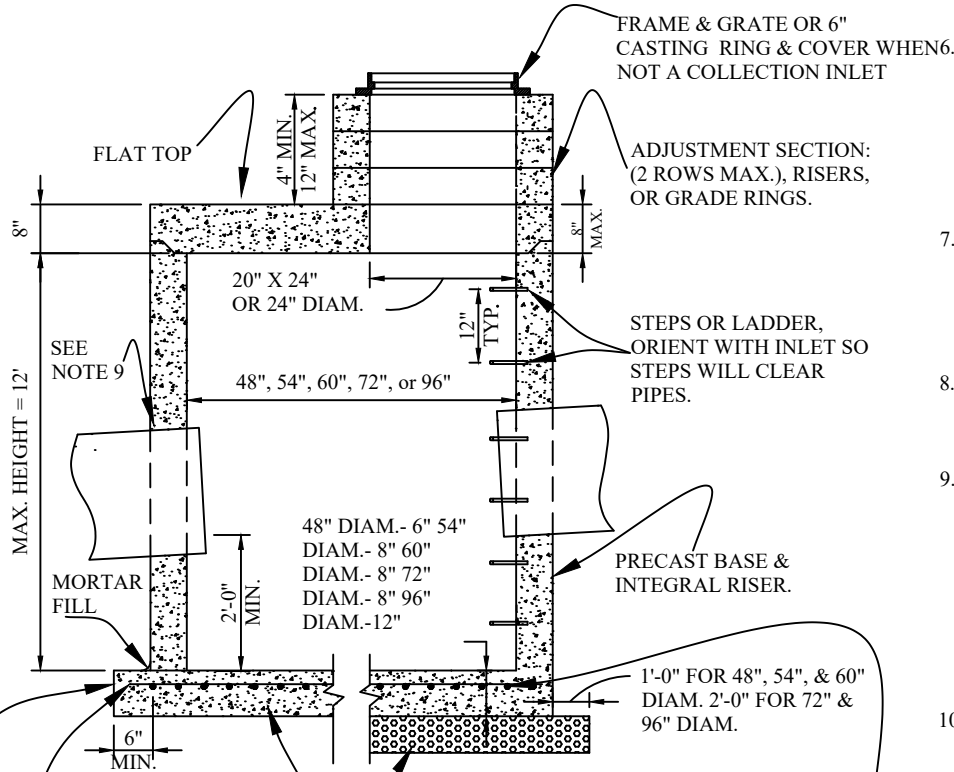

6. CATCH BASIN FRAMES AND GRATES OR COVERS SHALL BE IN ACCORDANCE WITH SEC. 7.05 OF THE STANDARD SPECIFICATIONS. MATING SURFACES SHALL BE FINISHED TO ASSURE NON-ROCKING FIT WITH ANY COVER POSITION.
7. ALL BASE REINFORCING STEEL SHALL HAVE A MIN. YIELD STRENGTH OF 60,000 PSI AND BE PLACED IN THE UPPER HALF OF THE BASE WITH 1" MIN. CLEARANCE.
8. MIN. SOIL BEARING VALUE SHALL EQUAL 3,300 POUNDS PER SQUARE FOOT.
9. INSTALL PIPE TO MANHOLE CONNECTION AS FOLLOWS: FOR HDPE USE KOR-N-SEAL FOR D.I. USE KOR-N-SEAL FOR PVC USE KOR-N-SEAL OR SAND COLLAR. FOR POLYETHYLENE (ADS) FOLLOW MANUFACTURER RECOMMENDATIONS.
10. "STORM" AND "CITY OF OTHELLO" SHALL BE CAST IN THE COVER.

REINFORCING STEEL

(FOR PRECAST BASE & INTEGRAL RISER ONLY)

- 48" DIAMETER** - 0.15 SQ. IN./FT. IN EACH DIRECTION.
- 54" DIAMETER** - 0.19 SQ. IN./FT. IN EACH DIRECTION.
- 60" DIAMETER** - 0.25 SQ. IN./FT. IN EACH DIRECTION.
- 72" DIAMETER** - 0.24 SQ. IN./FT. IN EACH DIRECTION.
- 96" DIAMETER** - 0.29 SQ. IN./FT. IN EACH DIRECTION.

REINFORCING STEEL (FOR SEPARATE BASES ONLY) 0.23 SQ. IN./FT. IN EACH DIRECTION FOR 48" DIAM. 0.19 SQ. IN./FT. IN EACH DIRECTION FOR 54" DIAM. 0.25 SQ. IN./FT. IN EACH DIRECTION FOR 60" DIAM. 0.35 SQ. IN./FT. IN EACH DIRECTION FOR 72" DIAM. 0.39 SQ. IN./FT. IN EACH DIRECTION FOR 96" DIAM.

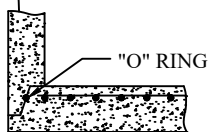

PRECAST BASE JOINT

CITY OF OTHELLO
STANDARD DETAILS
CATCH BASIN - TYPE 2 (48", 54", 60", 72" AND 96")

DETAIL A-18

#1	November, 2014
#2	June, 2016
#3	August, 2017
#3	March, 2021
REVISION #	DATE



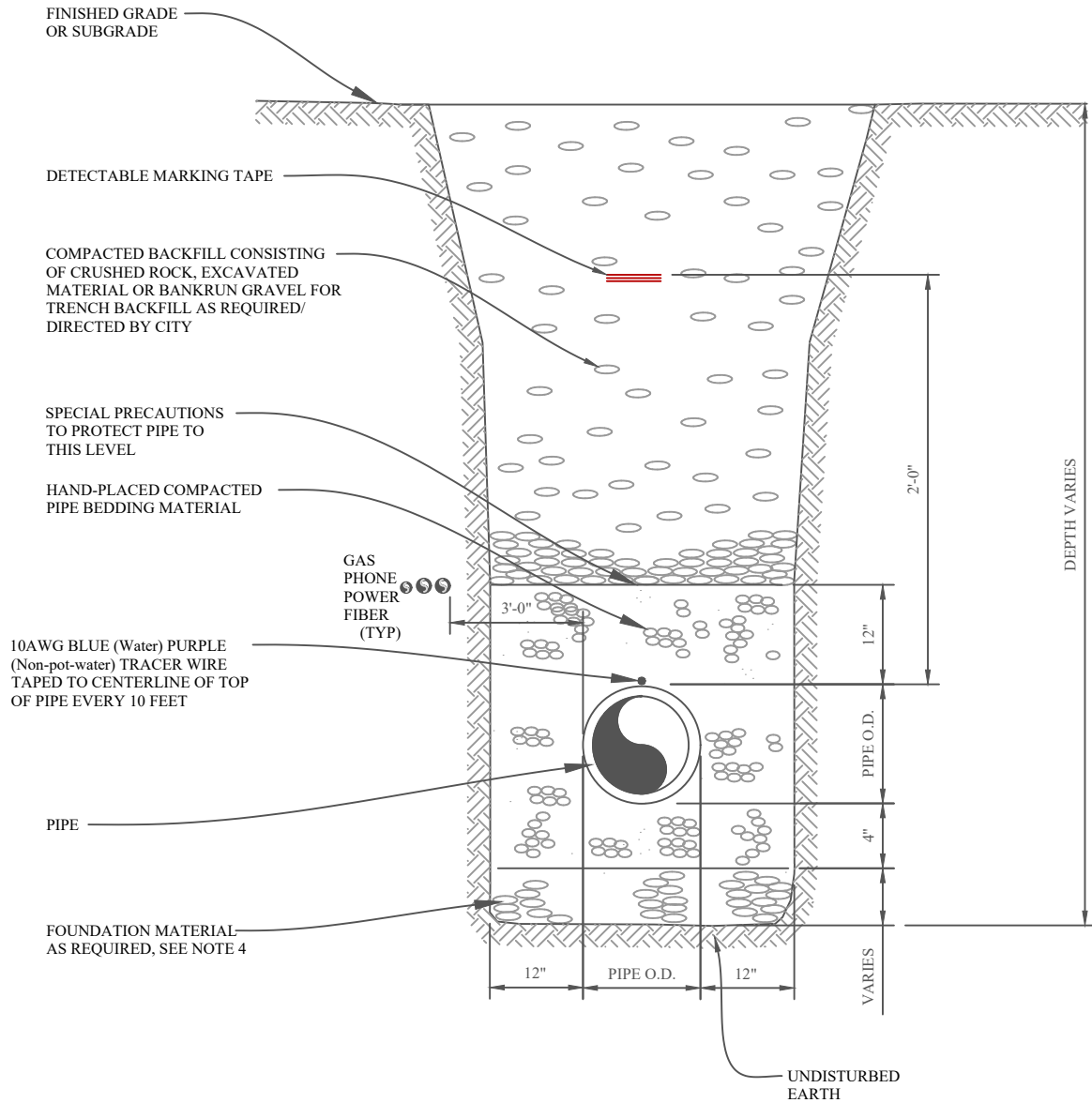

NOTES:

1. BACKFILL MATERIAL AND COMPACTION SHALL BE IN CONFORMANCE WITH THE CITY STANDARDS AND/OR THE STATE OR COUNTY PERMIT REQUIREMENTS (AS MAY BE REQUIRED).
2. ACTUAL SLOPE OF TRENCH SIDES TO BE DETERMINED BY CONTRACTOR TO FIT THE METHOD OF CONSTRUCTION AND ALL SAFETY REQUIREMENTS.
3. NO ADDITIONAL CONDUITS OR PIPES SHALL BE WITHIN (3') THREE-FEET OF THE WATER MAIN & SEWER MAIN.
4. EXCAVATE UNSUITABLE MATERIAL DOWN TO UNDISTURBED EARTH AND REPLACE WITH FOUNDATION MATERIAL PER SECTION 9-03.9 (1), "BALLAST", OF THE STANDARD SPECIFICATIONS, AS REQUIRED.
5. TRENCHES MAY BE BEDDED WITH CONTROLLED DENSITY FILL MATERIAL AS APPROVED BY CITY.
6. ALL CONSTRUCTION AND MATERIALS SHALL MEET THE CITY OF OTHELLO'S DESIGN STANDARDS AND BE APPROVED BY THE CITY.

D:\STREETS-2020\DETAILS 2021\DETAIL A-19-2021

CITY OF OTHELLO
STANDARD DETAILS
TYPICAL TRENCH SECTION
DETAIL A-19

#1	November, 2014
#2	June, 2016
#3	August, 2017
#3	March, 2021
REVISION #	DATE



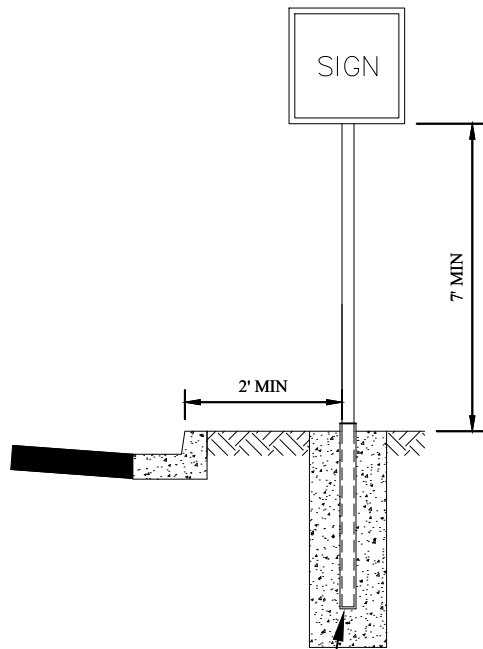

INSTALL SIGN POST AND BASE
PER WSDOT STANDARD PLAN
G-24.50.03 VERIFY
INSTALLATION TYPE WITH
CITY

SIGN SECTION VIEW

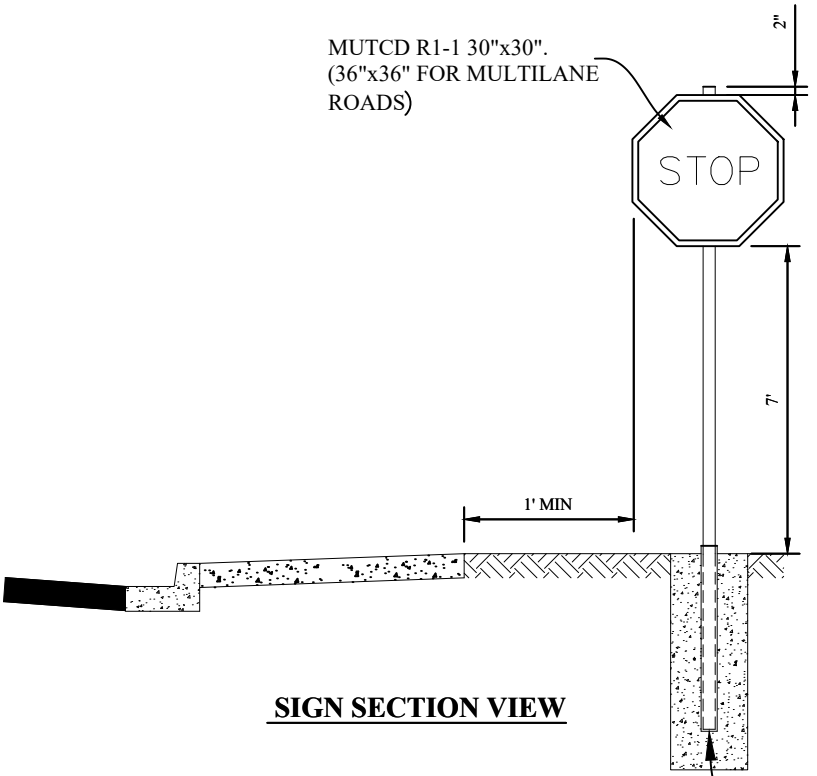

MUTCD R1-1 30"x30".
(36"x36" FOR MULTILANE
ROADS)

SIGN SECTION VIEW

INSTALL SIGN POST AND BASE
PER WSDOT STANDARD PLAN
G-24.50.03 VERIFY
INSTALLATION TYPE WITH
CITY

STOP/STREET SIGN INSTALLATION

NOTES:

1. PERFORATED SIGN POSTS AND SLEEVES SHALL BE FURNISHED AND INSTALLED BY THE CONTRACTOR.
2. MAINTAIN A MINIMUM OF 1' OF CLEARANCE BETWEEN THE SIGN EDGE AND THE BACK EDGE OF THE SIDEWALK.
3. STOP SIGNS WILL BE TYPICALLY PLACED 14' FROM THE FACE OF THE CURB ON THE STREET THEY APPROACH. EXACT LOCATION OF THE SIGN AND SLEEVE WILL BE ESTABLISHED BY THE CITY AT THE TIME OF INSTALLATION, PER MUTCD.
4. ALL CONSTRUCTION AND MATERIALS SHALL MEET THE CITY OF OTHELLO'S DESIGN STANDARDS AND BE APPROVED BY THE CITY.
5. NO PORTION OF THE SIGN SHALL OVERHANG THE SIDEWALK OR CURB.

NOTES:

1. PERFORATED SIGN POSTS AND SLEEVES SHALL BE FURNISHED AND INSTALLED BY THE CONTRACTOR.
2. MAINTAIN A MINIMUM OF 2' OF CLEARANCE BETWEEN THE SIGN POST AND THE FRONT EDGE OF THE CURB.
3. STOP/STREET SIGNS WILL BE TYPICALLY PLACED 14' FROM THE FACE OF THE CURB ON THE STREET THEY APPROACH. EXACT LOCATION OF THE SIGN AND SLEEVE WILL BE ESTABLISHED BY THE CITY AT THE TIME OF INSTALLATION.
4. ALL CONSTRUCTION AND MATERIALS SHALL MEET THE CITY OF OTHELLO'S DESIGN STANDARDS AND BE APPROVED BY THE CITY.
5. NO PORTION OF THE SIGN SHALL OVERHANG THE SIDEWALK OR CURB.

#1	November, 2014
#2	June, 2016
#3	March, 2021
REVISION #	DATE



MANHOLE FRAME AND COVER WITH "WATER" & "City of Othello" CAST ON COVER WITH 3" HIGH RAISED LETTERS (NON-SKID PATTERN) D&L Foundry Frames Mod.# A-2000-R1 Covers Mod# A-2000-25

4" x 24" PRECAST CONC
2 RINGS MAXIMUM.
MOTAR THE INSIDE IN PLACE &
GROUT THE INSIDE WITH
NON SHRINK GROUT. PLACE 5' x
5'x6" CLASS 3000 CONCRETE PAD
AROUND CASTING & TO A DEPTH OF
THE FLATTOP.

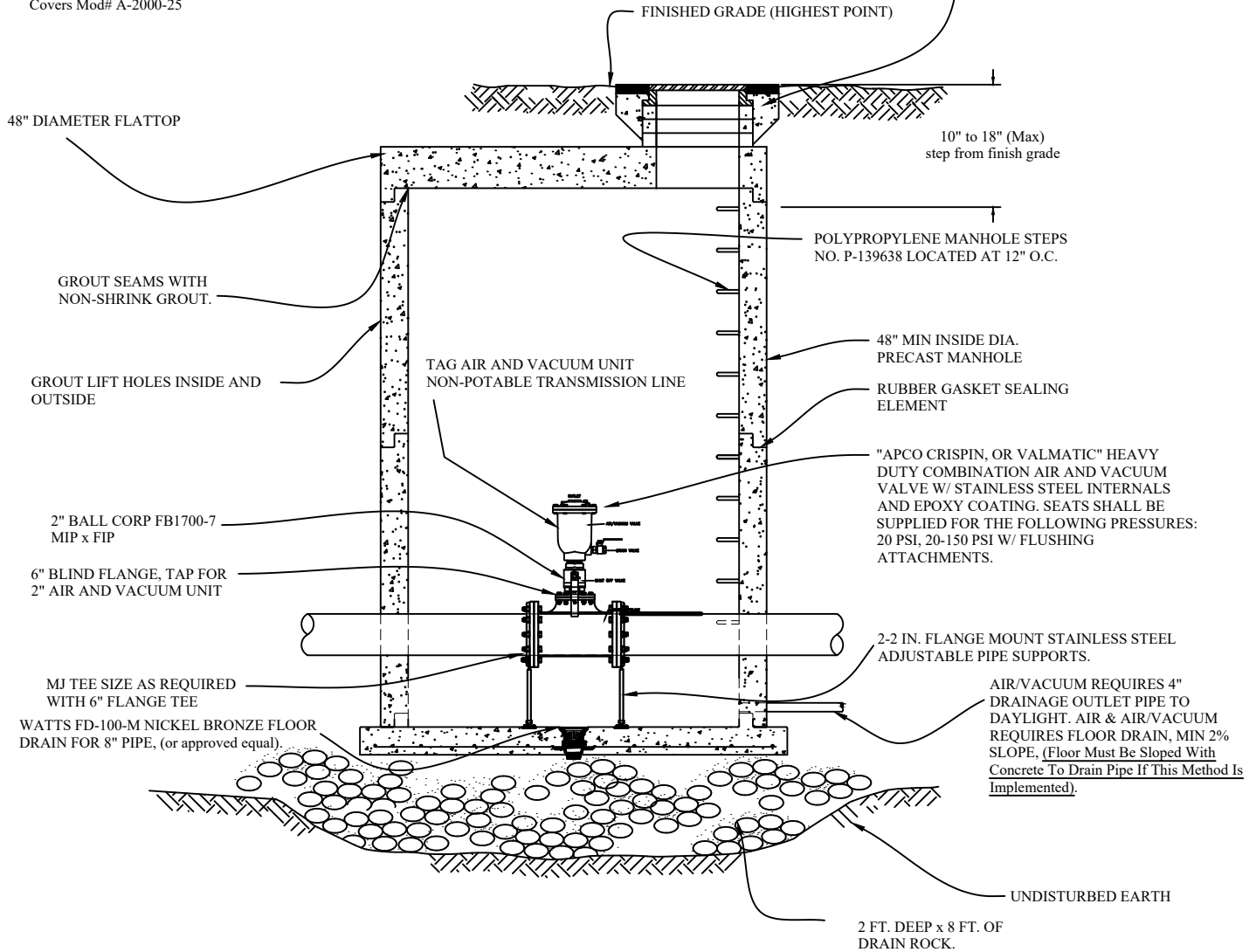

**AIR & AIR VACUUM RELEASE ASSEMBLY
SECTION DRAWING**

NOTE:

ALL CONSTRUCTION AND MATERIALS SHALL MEET THE CITY OF OTHELLO'S DESIGN STANDARDS AND BE APPROVED BY THE CITY.

**CITY OF OTHELLO
STANDARD DETAILS
AIR & AIR/ VACUUM RELEASE ASSEMBLY
DETAIL B-1**

#1	November, 2014
#2	June, 2016
#3	March, 2021
REVISION #	DATE



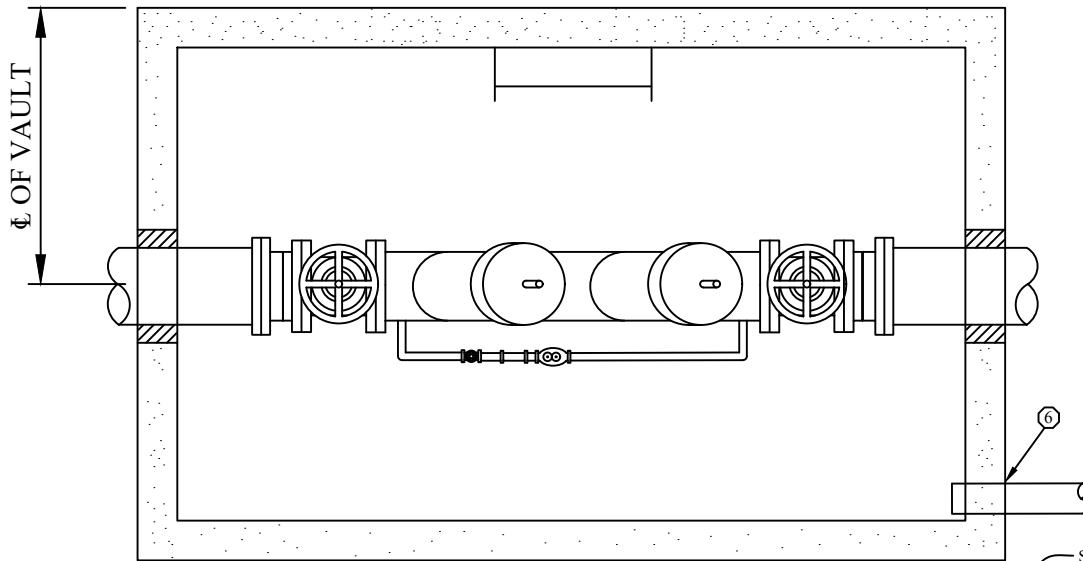

PLAN

SET VAULT 0.1' ABOVE FINISHED GRADE

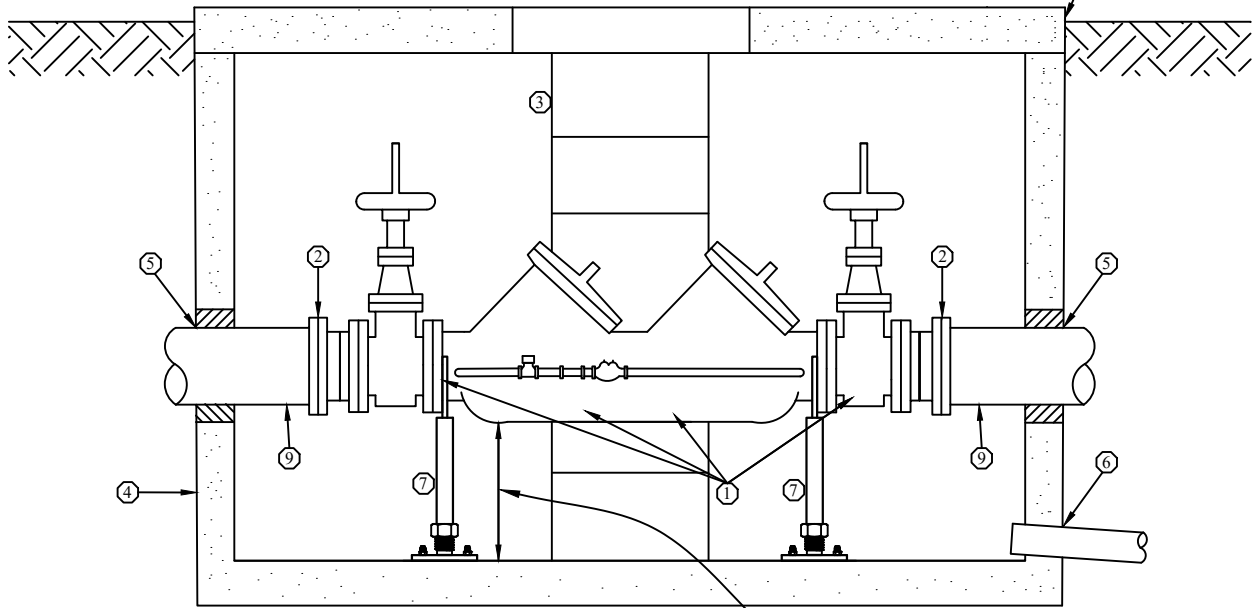

ELEVATION

MINIMUM 36" CLEARANCE FROM VAULT FLOOR

NOTES:

- ① DCDA DOUBLE CHECK DETECTOR ASSEMBLY ON THE USA BACKFLOW FOUNDATIONS APPROVAL LIST.
- ② UNI-FLANGE WITH SET SCREWS.
- ③ POLYPROPYLENE LADDER TO BE SECURED TO VAULT OR POLYPROPYLENE MANHOLE STEPS @ 12" ON CENTER.
- ④ CONCRETE VAULT (5'x9'x7'-2" INSIDE DIMENSIONS) WITH BILCO COVER (H20 LOADING) DOUBLE LEAF DESIGN. (HP PRE-CAST MODEL # 4484 or approved equal)
- ⑤ WATER TIGHT GROUT. RESTRAINT INLET/OUTLET PIPE WITH WELDED FLANGE, SHACKLE TO THRUST BLOCK, OR SHACKLED THROUGH VAULT.
- ⑥ 4" DRAIN TO SWALE, ATMOSPHERE, OR TO APPROVED DRYWELL.
- ⑦ ADJUSTABLE BOLT-ON FLANGE STAINLESS STEEL PIPE SUPPORTS (McMaster-CARR # 8427T811 or approved equal)
- ⑧ CL 53 D.I. MJ WITH MEGALUGS.

GENERAL NOTES:

- 1. ASSEMBLY SHALL BE MAINTAINED BY PROPERTY OWNER AND ANNUAL CERTIFICATION REQUIRED.
- 2. PAINT PIPING WITH MARKER PAINT MARINE ENAMEL. MARATHON 1065, TAHOE BLUE.

D:\WATER-2020\2021-DETAILS\DETAIL-B-2-2021

CITY OF OTHELLO
STANDARD DETAILS
DOUBLE CHECK DETECTOR ASSEMBLY
DETAIL B-2

#1	November, 2014
#2	June, 2016
#3	March, 2021
REVISION #	DATE



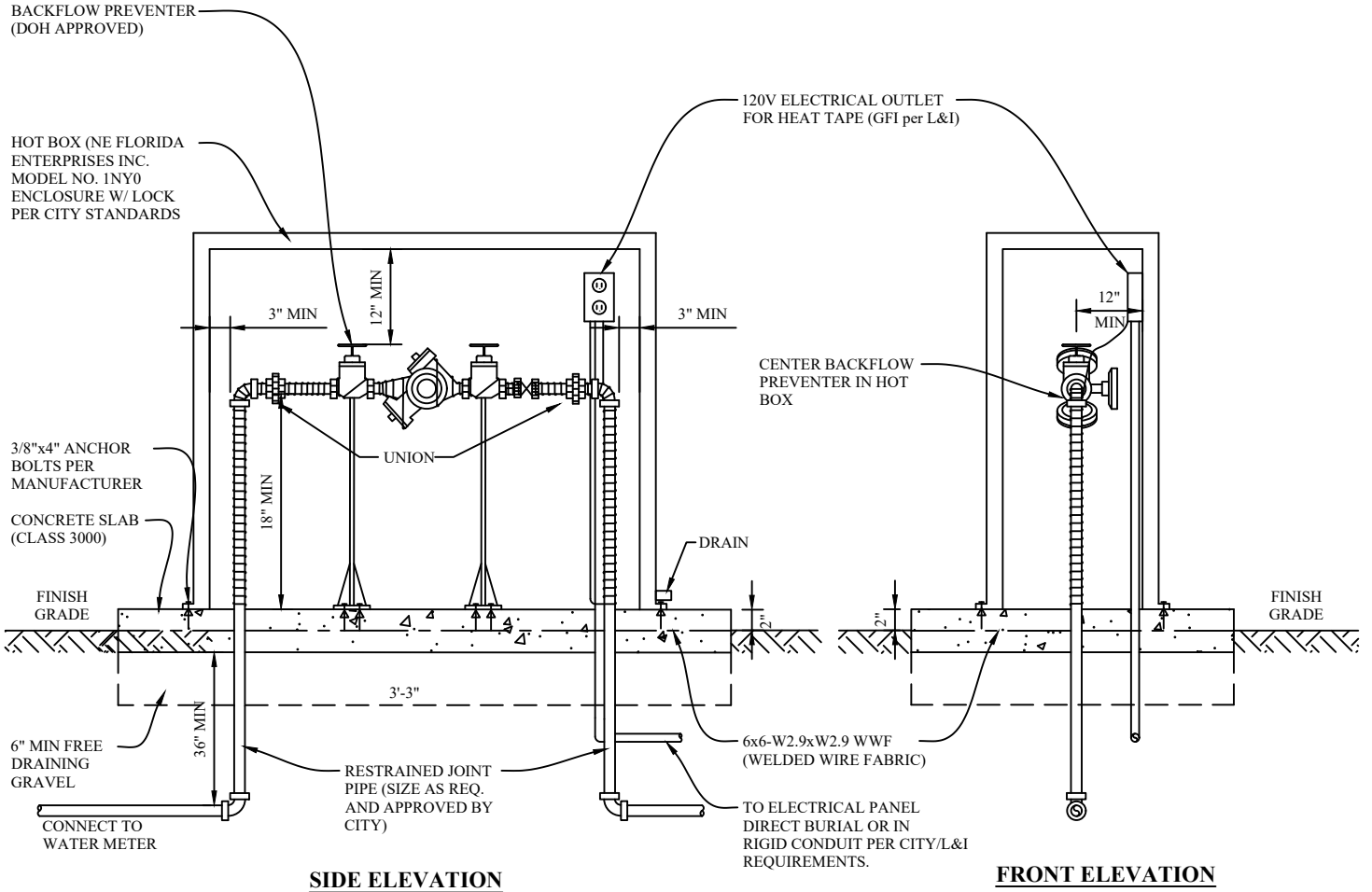

NOTES:

1. BOLT-ON FLANGE STAINLESS STEEL SUPPORTS FOR 2 1/2" AND LARGER DEVICES. (McMaster-Carr # 8427T811 or approved equal)

#1	November, 2014
#2	June, 2016
#3	March, 2021
REVISION #	DATE



TABLE 8		
APPROPRIATE METHODS OF BACKFLOW PROTECTION FOR PREMISES ISOLATION		
DEGREE OF HAZARD	APPLICATION CONDITION	APPROPRIATE APPROVED BACKFLOW PREVENTER
HIGH HEALTH CROSS-CONNECTION	BACKSIPHONAGE OR BACKPRESSURE BACKFLOW	AG, RPBA, OR RPDA
LOW CROSS-CONNECTION HAZARD	BACKSIPHONAGE OR BACKPRESSURE BACKFLOW	AG, RPBA, RPDA, DCVA, OR DCDA

TABLE 9

SEVERE* AND HIGH HEALTH CROSS-CONNECTION HAZARD PREMISES REQUIRING ISOLATION BY AG OR RPBA

- AGRICULTURAL (FARMS AND DAIRIES)
- BEVERAGE BOTTLING PLANTS
- CAR WASHES
- CHEMICAL PLANTS
- COMMERCIAL LAUNDRIES AND DRY CLEANERS
- PREMISES WHERE BOTH RECLAIMED WATER AND POTABLE WATER ARE PROVIDED
- FILM PROCESSING FACILITIES
- FOOD PROCESSING PLANTS
- HOSPITALS, MEDICAL CENTERS, NURSING HOMES, VETERINARY, MEDICAL AND DENTAL CLINICS, AND BLOOD PLASMA CENTERS
- PREMISES WITH SEPARATE IRRIGATION SYSTEMS USING THE PURVEYOR'S WATER SUPPLY AND WITH CHEMICAL ADDITION+
- LABORATORIES
- METAL PLATING INDUSTRIES
- MORTUARIES
- PETROLEUM PROCESSING OR STORAGE PLANTS
- PIERS AND DOCKS
- RADIOACTIVE MATERIAL PROCESSING PLANTS OR NUCLEAR REACTORS*
- SURVEY ACCESS DENIED OR RESTRICTED
- WASTEWATER LIFT STATIONS AND PUMPING STATIONS
- WASTEWATER TREATMENT PLANTS*
- PREMISES WITH AN UNAPPROVED AUXILIARY WATER SUPPLY INTERCONNECTED WITH THE POTABLE WATER SUPPLY

+ FOR EXAMPLE, PARKS, PLAYGROUNDS, GOLF COURSES, CEMETERIES, ESTATES, ETC.

* AN RPBA, FOR CONNECTIONS SERVING THESE PREMISES, ARE ACCEPTABLE ONLY WHEN USED IN COMBINATION WITH AN IN-PLANT APPROVED AIR GAP; OTHERWISE, THE PURVEYOR SHALL REQUIRE AN APPROVED AIR GAP AT THE SERVICE CONNECTION.

GENERAL NOTES:

1. ALL BACKFLOW PREVENTION ASSEMBLIES ARE TO BE INSTALLED IN ACCORDANCE WITH WAC 246-290-490
2. THE ABOVE TABLES WERE REPRODUCED FROM THE WAC 246-290-490
3. ALL BACKFLOW PREVENTION ASSEMBLIES TO BE INSTALLED SHALL BE APPROVED FOR INSTALLATION IN WASHINGTON STATE AND BE ON THE LATEST VERSION OF THE USC LIST OF APPROVED BACKFLOW PREVENTION ASSEMBLIES

**CITY OF OTHELLO
STANDARD DETAILS
BACKFLOW PREVENTION
DETAIL B-4**

#1	November, 2014
#2	June, 2016
#3	March, 2021
REVISION #	DATE



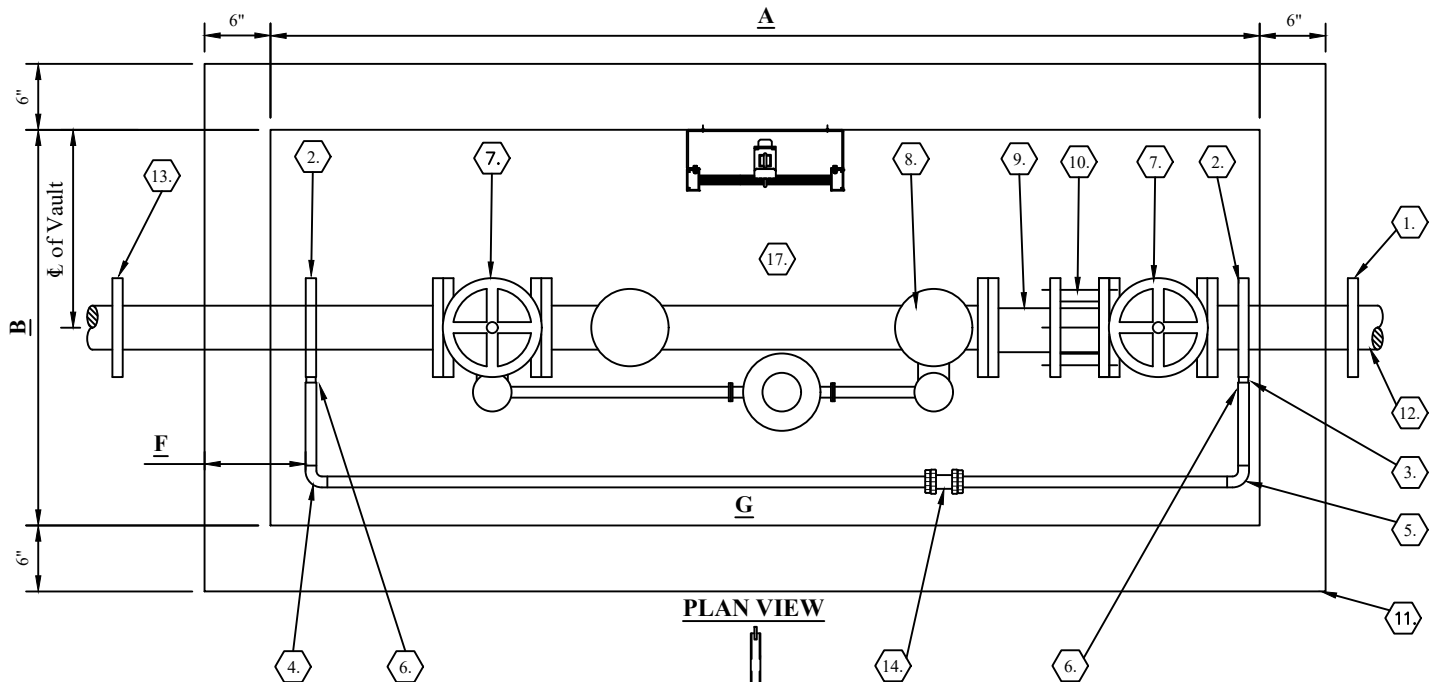

PLAN VIEW

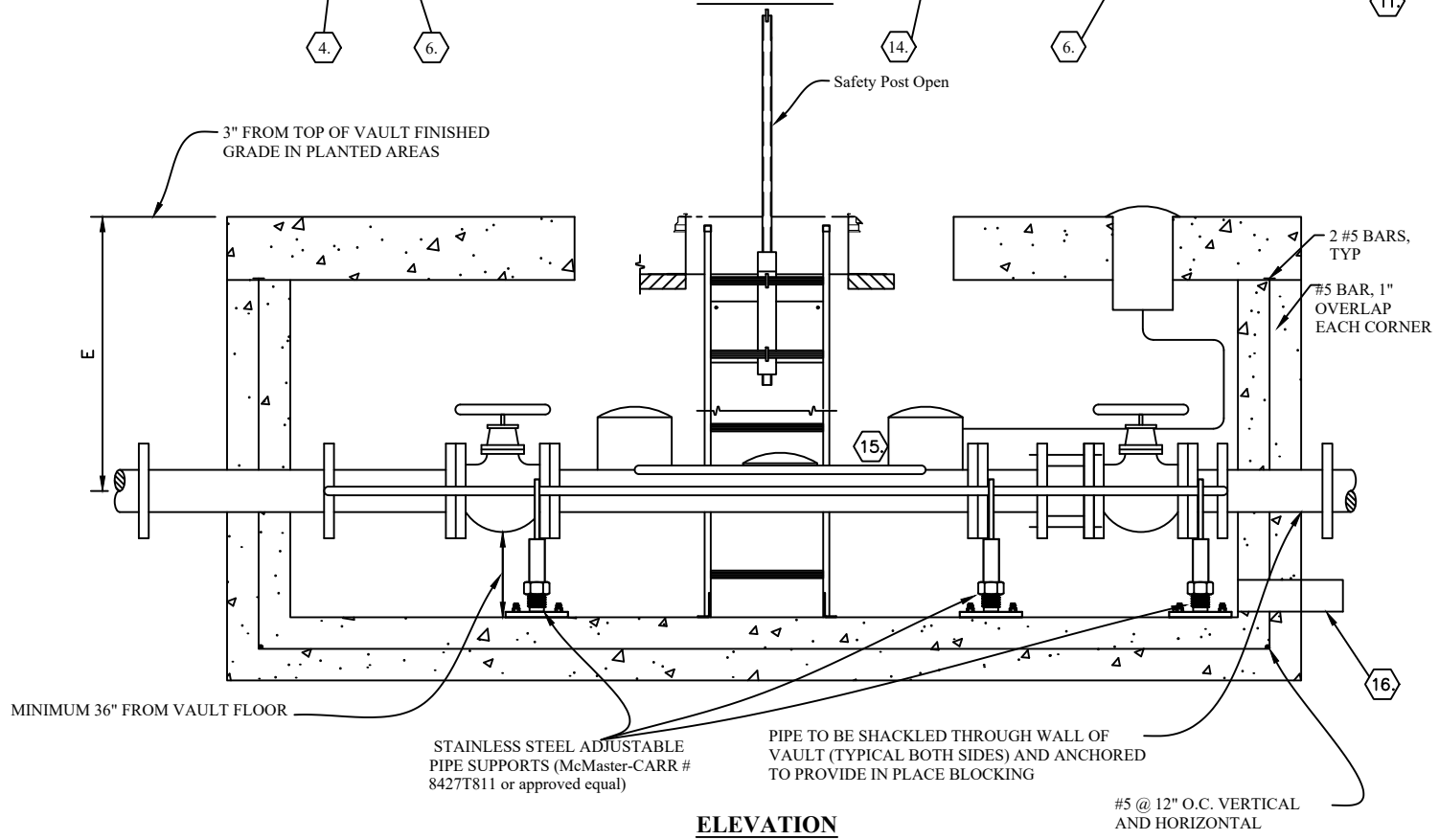

ELEVATION

NOTES:

1. INSTALL 4" DRAIN PIPE TO SWALE, ATMOSPHERE, OR APPROVED DRYWELL
2. BACKFLOW PREVENTOR REQUIRED FOR ALL FIRE LINES AND IRRIGATION LINES, IN SEPARATE VAULTS OR IN BUILDINGS AS PER CITY APPROVAL
3. BRASS DOES NOT NEED TO BE PAINTED, ALL OTHER PIPE TO BE PAINTED WITH MARINE ENAMEL, MARATHON 1065 TAHOE BLUE.
4. RADIO READ HEAD NEEDS TO EXTEND THROUGH THE LID OF THE BOX, AS PER THE MANUFACTURER RECOMMENDATION.
5. CONCRETE VAULT (5'x9'x7'-2" INSIDE DIMENSIONS) WITH BILCO COVER (H2O LOADING) DOUBLE LEAF DESIGN. (H² PRE-CAST MODEL # 4484 or approved equal)

D:\WATER-2020\2021-DETAILS\DETAIL-B-5.01-2021

CITY OF OTHELLO
STANDARD DETAILS
METER AND METER VAULT ASSEMBLY (3" THROUGH 10")
DETAIL B-5.01

#1	November, 2014
#2	June, 2016
#3	March, 2021
REVISION #	DATE



MATERIAL LIST

1. 2-FLEX CPLG TO FIT ROCKWELL 441 (4"x3" REDUCER, MJ FOR 3" METER)
2. 2-DOUBLE STRAP SERVICE (STAINLESS STEEL BAND) ROMAC 101 WITH IPS TAP, OR EQUAL.
3. 3-STRAIGHT CPLG BRASS TO OUTSIDE I.P. THREAD MUELLER H-15425, H-15428 110 COMP., OR EQUAL.
4. 1 1/4" BEND CPLG, BRASS TO BRASS, FORD.
5. 1 1/4" BEND CPLG, BRASS TO OUTSIDE I.P. THREAD, MUELLER H-15530, OR EQUAL.
6. 1" BALL VALVE WITH PADLOCK WING OFF OF SADDLE OR DIRECT MAIN TAP.
7. 2-RESILIENT SEAT GATE VALVE, FLxFL, (RISING STEM).
8. 3" TO 10" COMPOUND METER WITH STRAINER, SIZE TO BE #1 BADGER RADIO READ, AS SPECIFIED BY CITY AND FURNISHED BY CONTRACTOR/DEVELOPER.
9. 14 DI ADAPTER, FLxPE (LENGTH TO FIT).
10. 1-CPLG ADAPTER., FL ROCKWELL 912, OR APPROVED EQUAL.
11. CAST IN PLACE OR PRECAST CONCRETE VAULT WITH (H2O) BILCO HATCH (SIZE AND LOCATION TO BE APPROVED BY THE CITY).
12. WELDED FL RESTRAINT OR SHACKLE TO THRUST BLOCK TO PREVENT MOVEMENT IF METER IS REMOVED.
13. INSULATED CPLG TO 3" CU SERVICE.
14. UNION.
15. INSTALL POLYPROPYLENE STEPS WITH TELESCOPIC RISER, FASTEN TO WALL WITH STAINLESS STEEL FASTENERS AT MAXIMUM ONE FOOT INTERVALS.
16. PROVIDE 4" DRAIN PIPE (AT SUMP) TO SWALE, ATMOSPHERE, OR APPROVED DRYWELL, MIN. SLOPE = 2%.
17. WATER METER LAY LENGTH IN PIT WITH SCREEN (5 TIMES PIPE DIA. UP STREAM 3 TIMES DOWN STREAM PIPE DIA.) STRAIGHT PIPE.

NOTES:

1. METERS SHALL BE AS REQUIRED BY THE CITY (RADIO READ BADGER) METERS SHALL READ IN CUBIC FEET.
5. CONCRETE VAULT (5'x9'x7'-2" INSIDE DIMENSIONS) WITH BILCO COVER (H2O LOADING) DOUBLE LEAF DESIGN. (H² PRE-CAST MODEL # 4484 or approved equal)
3. ALL PIPE AND FITTINGS 4" AND LARGER SHALL BE DUCTILE IRON.
4. PIPING FROM MAIN TO VAULT SHALL BE AS SHOWN IN THE TABLE BELOW. PROVIDE TEE WITH VALVE ON DISTRIBUTION MAIN.
5. ALL PIPING SHALL BE PAINTED (TWO COATS) WITH MARINE ENAMEL, MARATHON 1065. TAHOE BLUE.
6. BACKFLOW DEVICE REQUIREMENT SHALL BE DETERMINED BY THE CITY.
7. ALL PROPOSALS ARE TO BE APPROVED BY THE CITY.
8. RADIO READ HEAD TO EXTEND THROUGH THE PIT LID AS PER MANUFACTURER RECOMMENDATION.
9. ALL CONSTRUCTION AND MATERIALS SHALL MEET THE CITY OF OTHELLO'S DESIGN STANDARDS AND BE APPROVED BY THE CITY

METER SIZE	MAIN-LINE	BYPASS	A	B	C	D	E	F	G
3"-4"	4" DI	1-1/2" BRASS	7'-6"	3'-0"	9'-1/2"	6"	2'-8"	9"	4'
6"	6" DI	2" BRASS	9'-6"	3'-6"	12"	6"	2'-8"	9"	4"
8"	8" DI	4" DI	11'-0"	4'-0"	12"	9"	3'-6"	14"	6"
0'-10"	10" DI	4" DI	13'-0"	5'-0"	16"	12"	4'-0"	16"	6"

CITY OF OTHELLO
 STANDARD DETAILS
 METER AND METER VAULT ASSEMBLY (3" THROUGH 10")
DETAIL B-5.02

#1	November, 2014
#2	June, 2016
#3	March, 2021
REVISION #	DATE



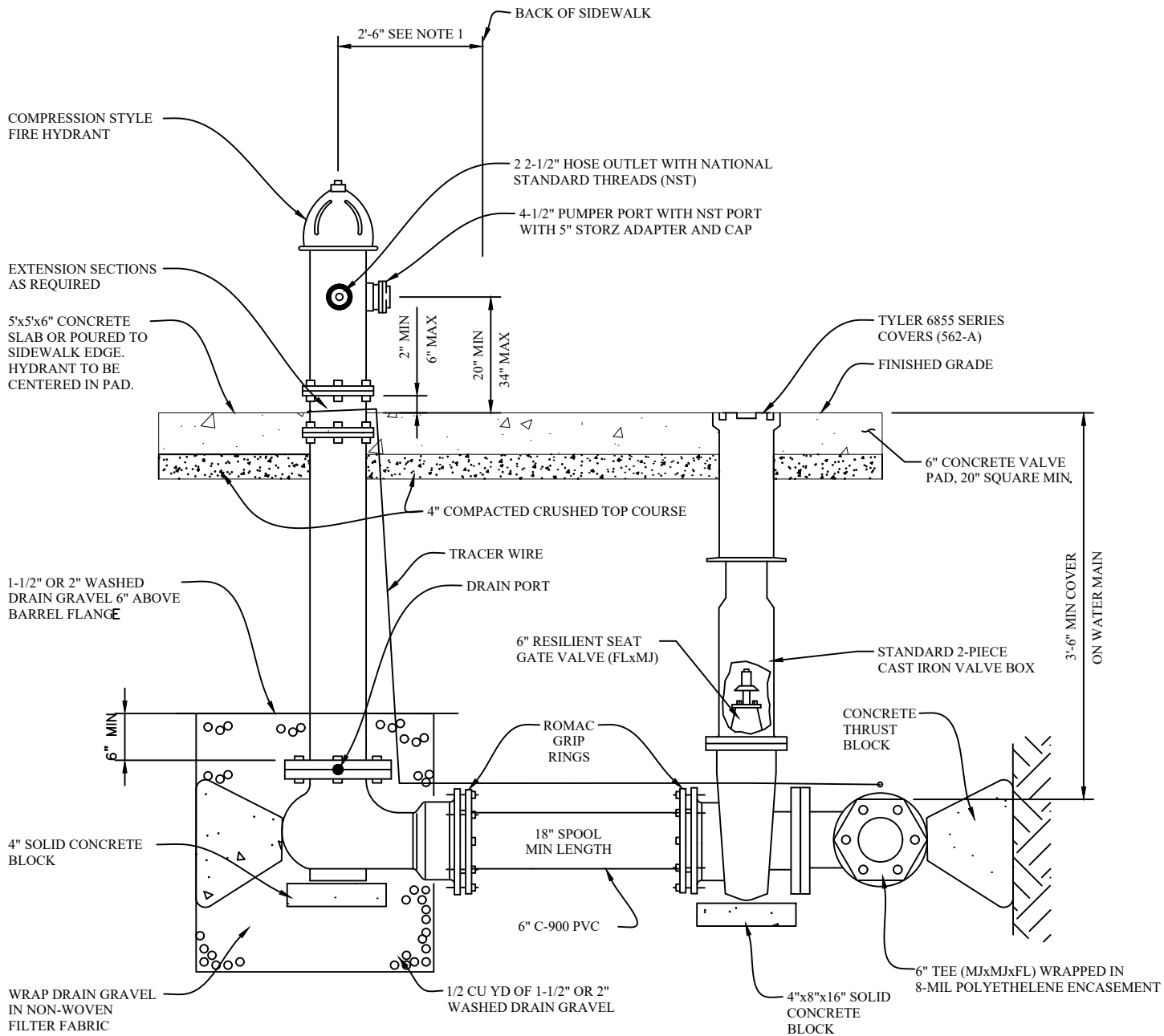

NOTES:

1. 2'-6" FROM BACK OF SIDEWALK OR 6' FROM BACK OF CURB OR 3' INSIDE RIGHT-OF-WAY.
2. PROVIDE 8" PIPE SIZE IF OVER 60' FROM MAINLINE.
3. PROVIDE MIN. 5' CLEAR AND LEVEL AREA AROUND HYDRANT. 2'-6" ALL AROUND MEASURED FROM OPERATOR NUT. GUARD POSTS REQUIRED IF IN PARKING AREA OR IF CONSIDERED A HAZARDOUS AREA AND DEEMED NECESSARY BY THE CITY.
4. PAINT FIRE HYDRANT AND GUARD POSTS WITH TWO (2) COATS CAT YELLOW PAINT AFTER INSTALLATION.
5. FIRE HYDRANT SHALL BE WATEROUS WB67250, MH-1295.
6. FOR OTHER SPECIFICATIONS, USE WSDOT/APWA STANDARD SPECIFICATIONS.
7. ALL CONSTRUCTION AND MATERIALS SHALL MEET THE CITY OF OTHELLO'S DESIGN STANDARDS AND BE APPROVED BY THE CITY.

#1	November, 2014
#2	June, 2016
#3	March, 2021
REVISION #	DATE



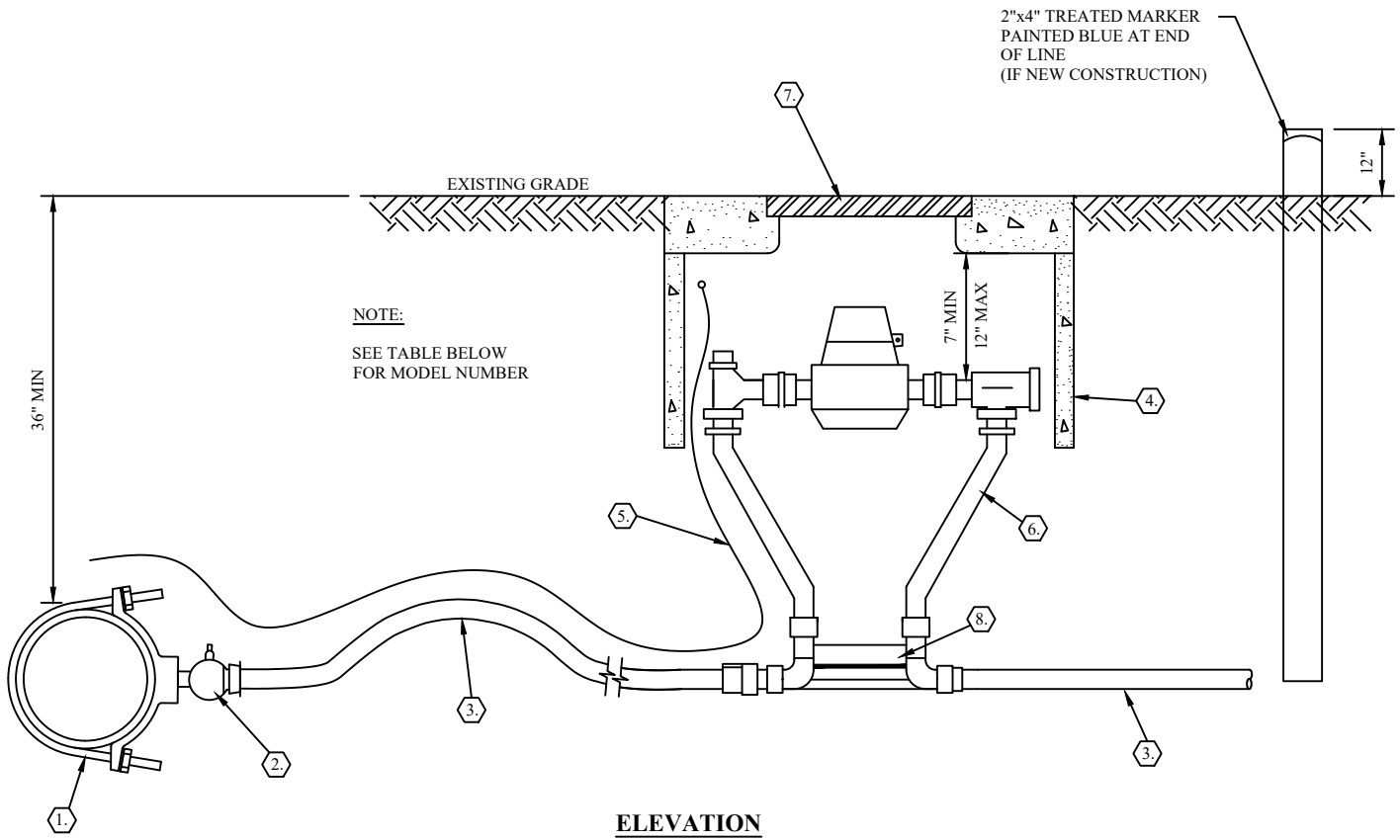

DESCRIPTION, ALL NEW CONSTRUCTION	MAKE OR RATING	1"-MODEL #
1. STAINLESS BAND/EPOXY COAT	FORD OR EQUAL	202S-905x11P
2. CORP STOP/BALL VALVE	FORD OR EQUAL	FB 1100-4Q
3. COPPER PIPE WITH 3' PIGTAIL		TYPE K
4. METER BOX, 24" DEPTH MIN.	OLD CASTLE	1324BCF
5. TRACER WIRE THHN	CU SOLID WIRE	10 GAUGE
6. METER SETTER	FORD OR EQUAL	VBH74-24W-44-44-Q
7. DUCTILE IRON MAX VIEW COVER	OLD CASTLE	
8. TIE BAR	FORD OR EQUAL	

NOTES:

- CONTRACTOR SHALL MAKE COMPLETE CONNECTION IN GOOD WORKING ORDER AND SHALL PROVIDE ALL NECESSARY FITTINGS, COUPLINGS, ETC.
- CONTRACTOR TO NOTIFY THE CITY OF ANY EXISTING DAMAGED METER BOXES PRIOR TO ANY EXCAVATION FOR THESE SERVICE CONNECTIONS. ANY DAMAGE AS A RESULT OF THE CONTRACTOR'S WORK SHALL RESULT IN NEW METER BOXES OF EQUAL TYPE AND MATERIAL TO BE INSTALLED AT THE CONTRACTORS EXPENSE.
- ANY DAMAGE DONE TO EXISTING METERS AS A RESULT OF THE CONTRACTOR'S OPERATIONS SHALL BE REPAIRED BY THE CITY'S PERSONNEL AND ALL COSTS OF REPAIR OR REPLACEMENT, SHALL BE PAID BY THE CONTRACTOR.
- ALL FITTINGS SHALL BE BRASS.
- TRACER WIRE FROM MAIN TO SERVICE METER SHALL BE INSTALLED IN ALL INSTALLATIONS. WIRE SHALL BE VISIBLE IN SERVICE METER BOX.
- ALL CONSTRUCTION AND MATERIALS SHALL MEET THE CITY OF OTHELLO'S DESIGN STANDARDS AND BE APPROVED BY THE CITY.
- COPPER SERVICE LINE SHALL BE CONTINUOUS WITH NO JOINTS FROM WATER MAIN TO METER SETTER
- MIN. OF (3') THREE-FOOT PIGTAIL OUT OF METER SERVICE BOX TO PROPERTY

CITY OF OTHELLO
STANDARD DETAILS
1" WATER SERVICE W/ METER SETTER
DETAIL B-7

#1	November, 2014
#2	June, 2016
#3	March, 2021
REVISION #	DATE



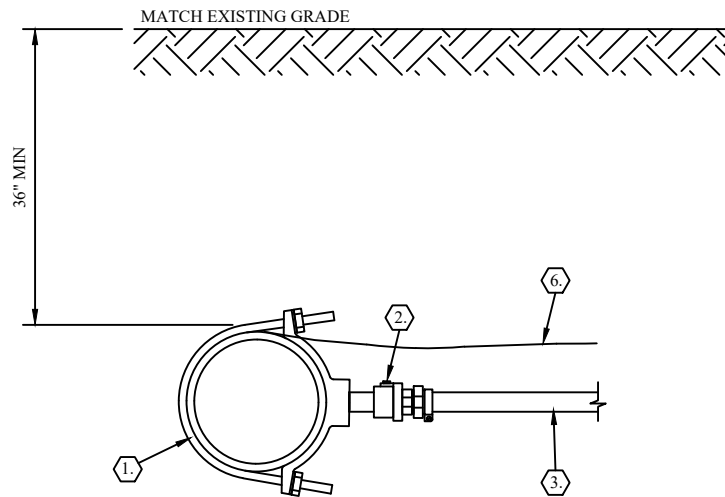
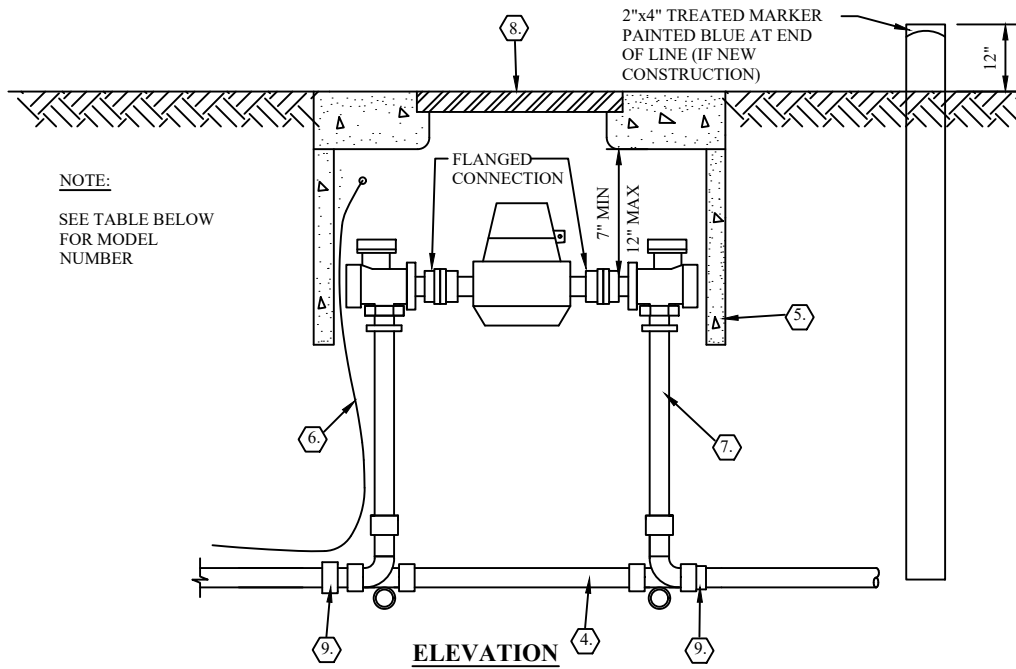

DESCRIPTION, ALL NEW CONSTRUCTION	MAKE OR RATING	1-1/2"	2"
1. DOUBLE STRAP STAINLESS STEEL BAND	ROMAC OR EQUAL	202 IPT	202 IPT
2. CORPORATION STOP	FORD OR EQUAL	FB 1102-6	FB 1102-7
3. SCHEDULE 80 PVC/ BLUE PEX WITH CRUSH SLEEVES			
4. TIE BAR	FORD OR EQUAL		
5. METER BOX, 24" DEPTH REQ. MIN	OLD CASTLE	1730BCF	1730BSF
6. TRACER WIRE THHN	10 GA COPPER WIRE	SOLID	SOLID
7. METER SETTER	FORD OR EQUAL	VBH76-44-77-66	VBH77-44-77-77
8. LID METAL (D.I. MAX VIEW COVER)	OLD CASTLE		
9. COUPLING	FORD OR EQUAL	C87-66	C87-77

NOTES:

- THE SERVICE LINE TO LOTS OVER 16,000 SF SHALL CONSIST OF 2" COPPER OR 2" RIGID SCHEDULE 80. THE 2" LINE SHALL TERMINATE WITH A 2" BALL VALVE 3' FROM THE STREET RIGHT-OF-WAY LINE INCLUDING A TRACER WIRE CONNECTED TO THE WIRE ON TOP OF THE LINE AND EXTENDING UP THE TREATED 2"x4" MARKER BURIED AT THE END OF BALL VALVE. BEDDING MATERIAL SHALL BE SAND.
- ALL CONSTRUCTION AND MATERIALS SHALL MEET THE CITY OF OTHELLO'S DESIGN STANDARDS AND BE APPROVED BY THE CITY.

D:\WATER-2020\2021-DETAILS\DETAIL-B-8-2021

CITY OF OTHELLO
STANDARD DETAILS
1-1/2" & 2" WATER SERVICE
DETAIL B-8

#1	November, 2014
#2	June, 2016
#3	March, 2021
REVISION #	DATE



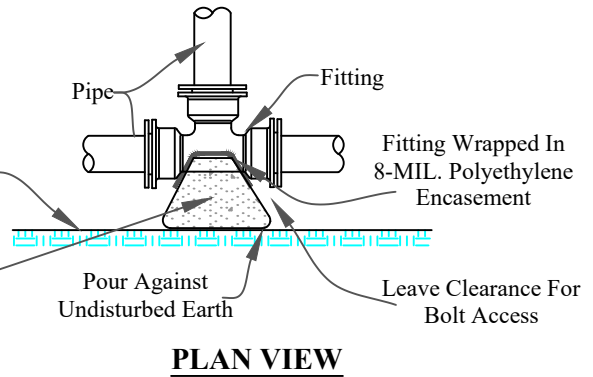
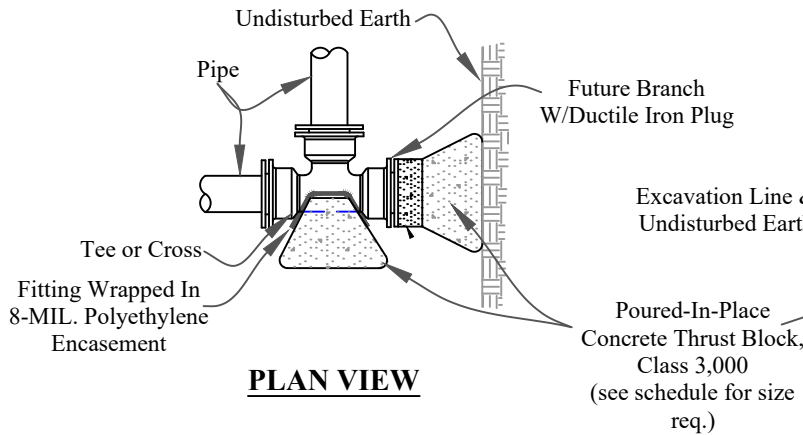
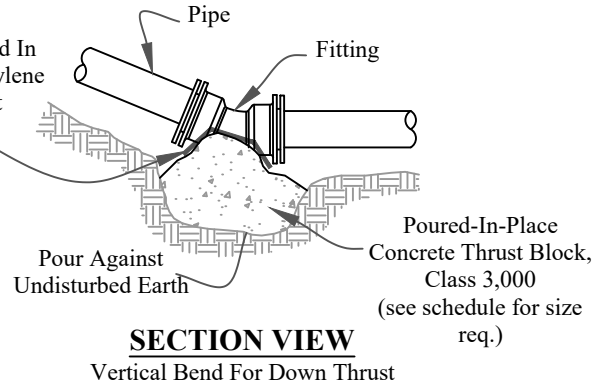
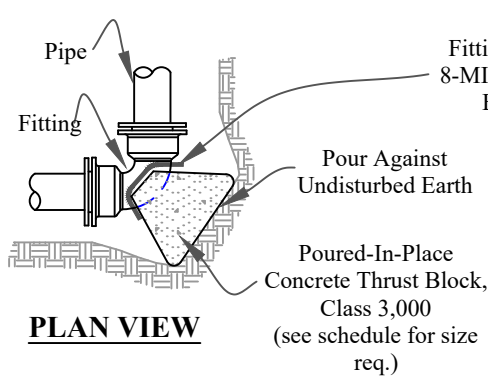

MINIMUM THRUST BLOCK BEARING AREA REQUIRED *				
SIZE	TEES AND DEAD ENDS	90° BEND	45° BEND	22 1/2° BEND
4" OR LESS	2 SF	3 SF	2 SF	1 SF
6"	4 SF	5 SF	3 SF	2 SF
8"	6 SF	8 SF	5 SF	3 SF
10"	10 SF	13 SF	7 SF	4 SF
12"	13 SF	19 SF	10 SF	6 SF
16"	18 SF	25 SF	14 SF	7 SF
18"	23 SF	32 SF	18 SF	9 SF

* BASED ON A PIPE TEST PRESSURE OF 250 PSI AND BEARING STRENGTH OF SOIL AT 3000 LBS/SQ. FT. FOR OTHER CONDITIONS REVISE AND INCREASE ACCORDINGLY AS APPROVED BY THE ENGINEER.

NOTES:

- THRUST BLOCKS ARE TO EXTEND TO UNDISTURBED GROUND.
- INCREASE THRUST BLOCK AREA BY 50% IN SAND.
- WRAP ALL FITTINGS WITH 8-MIL POLYETHYLENE ENCASUREMENT.
- CONCRETE SHALL NOT COME INTO CONTACT WITH PIPE, VALVES, OR FITTINGS.
- ALL THRUST BLOCKS ARE REQUIRED TO BE FORMED ON THE SIDES WITH SUITABLE MATERIAL AND THE BACK AGAINST UNDISTURBED EARTH.
- ALL CONSTRUCTION AND MATERIALS SHALL MEET THE CITY OF OTHELLO'S DESIGN STANDARDS AND BE APPROVED BY THE CITY.

CITY OF OTHELLO
STANDARD DETAILS
THRUST BLOCK DETAIL
DETAIL B-9

#1	November, 2014
#2	June, 2016
#3	March, 2021
REVISIONS	DATE



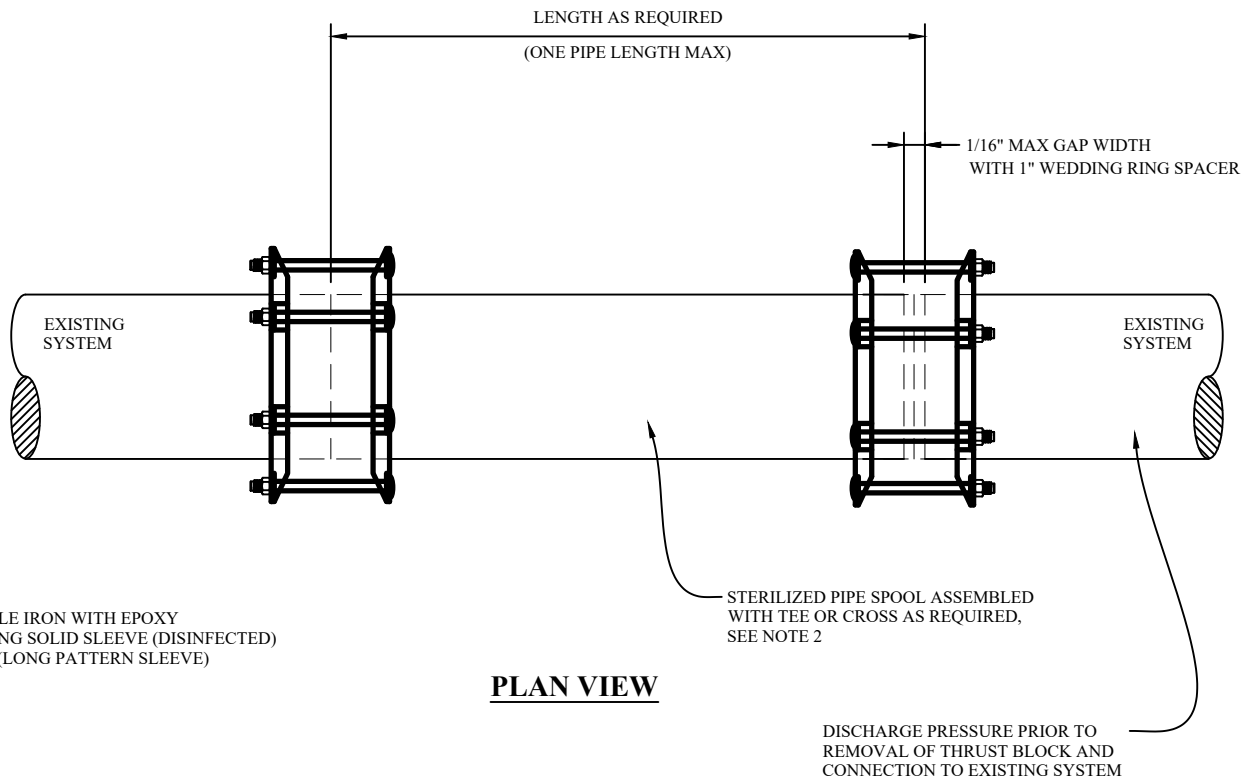

DUCTILE IRON WITH EPOXY COATING SOLID SLEEVE (DISINFECTED) TYPE. (LONG PATTERN SLEEVE)

STERILIZED PIPE SPOOL ASSEMBLED WITH TEE OR CROSS AS REQUIRED, SEE NOTE 2

NOTES:

1. DEFLECTION SHALL NOT EXCEED 5° PER COUPLER END, AS PER MANUFACTURE'S SPECIFICATIONS. (ROMAC 501 & MARCO HP 501 COUPLERS OR APPROVED EQUAL)
2. ADDITIONAL "IN-LINE" VALVE(S) MAY BE REQUIRED AT THE DIRECTIONAL OF THE CITY.
3. ALL CONSTRUCTION AND MATERIALS SHALL MEET THE CITY OF OTHELLO'S DESIGN STANDARDS AND BE APPROVED BY THE CITY.
4. PUBLIC WORKS PERSONNEL SHALL WITNESS ALL WORK WHILE WATER SYSTEM IS OPEN, 24 HOURS NOTICE REQUIRED.

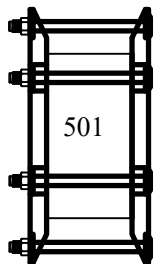

ROMAC 501 DUCTILE IRON WITH EPOXY COATING SOLID SLEEVE. (DISINFECT BEFORE INSTALL)

ELEVATION

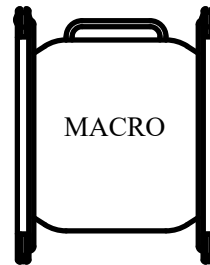

ROMAC MACRO HP 501 DUCTILE IRON WITH EPOXY COATING SOLID SLEEVE. (DISINFECT BEFORE INSTALL)

ELEVATION

CITY OF OTHELLO
STANDARD DETAILS
CUT IN CONNECTION
DETAIL B-10

#1	November, 2014
#2	June, 2016
#3	March, 2021
REVISION #	DATE



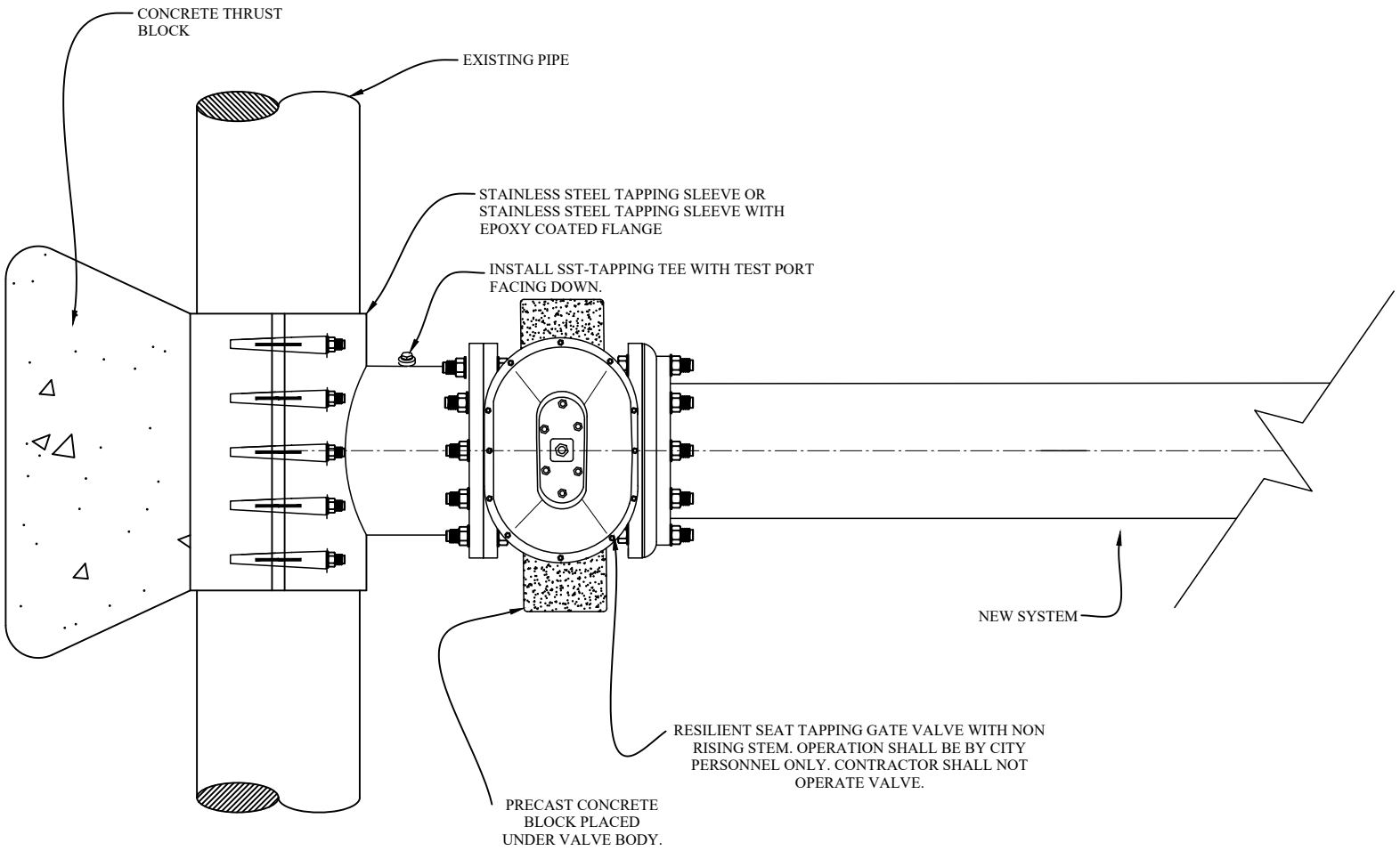

PLAN VIEW

NOTES:

1. THRUST BLOCKS ARE TO EXTEND TO UNDISTURBED GROUND.
2. INCREASE THRUST BLOCK AREA BY 50% IN SAND.
3. WRAP ALL FITTINGS WITH 8-MIL POLYETHYLENE ENCASEMENT.
4. CONCRETE SHALL NOT COME INTO CONTACT WITH PIPE, VALVES, OR FITTINGS.
5. ALL THRUST BLOCKS ARE REQUIRED TO BE FORMED ON THE SIDES WITH SUITABLE MATERIAL AND THE BACK AGAINST UNDISTURBED EARTH.
6. CONTRACTOR SUPPLIES ALL PARTS.
7. ALL CONSTRUCTION AND MATERIALS SHALL MEET THE CITY OF OTHELLO'S DESIGN STANDARDS AND BE APPROVED BY THE CITY.

CITY OF OTHELLO
 STANDARD DETAILS
 WET TAP CONNECTION
DETAIL B-11

#1	November, 2014
#2	June, 2016
#3	March, 2021
REVISION #	DATE



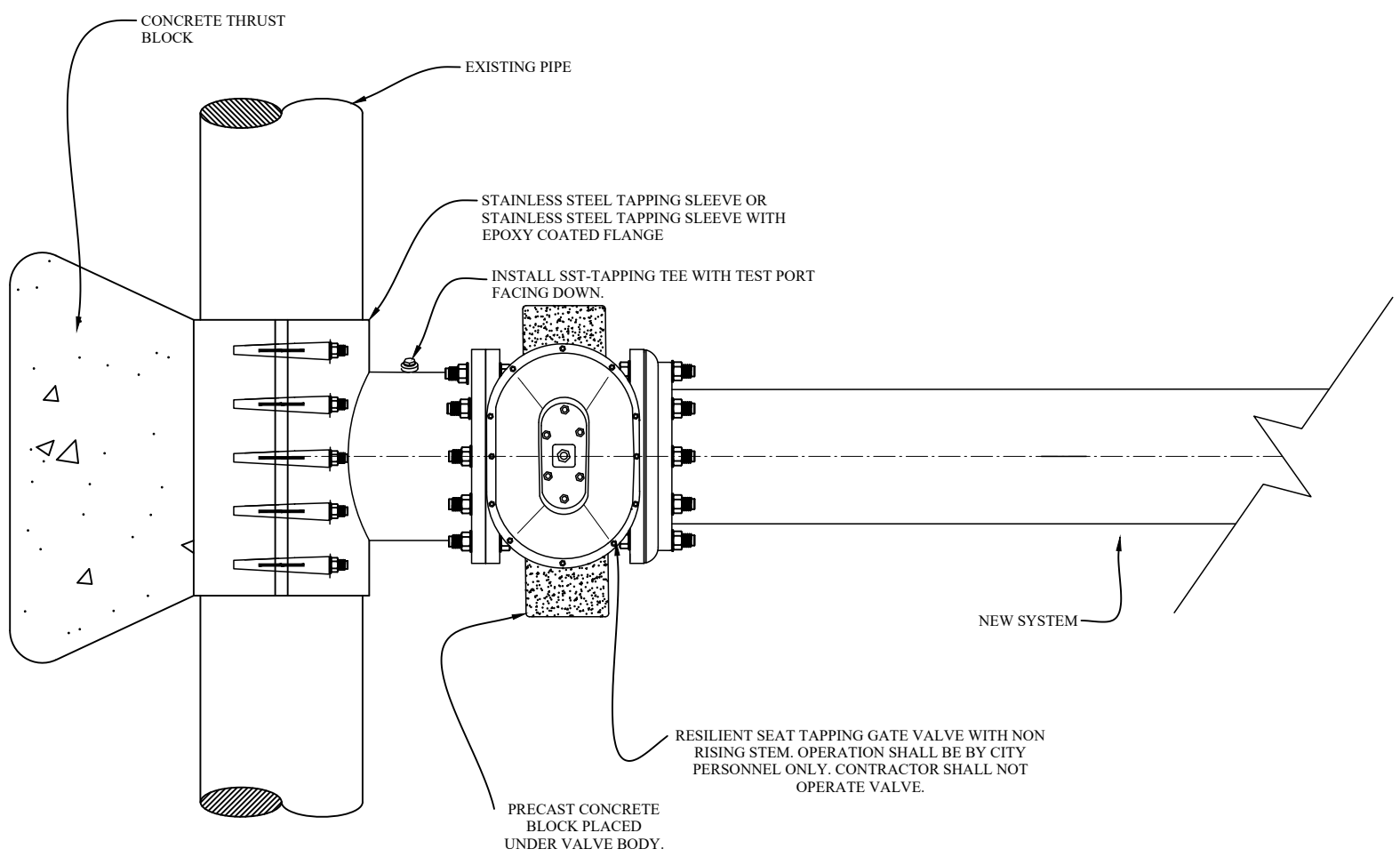

PLAN VIEW

NOTES:

1. THRUST BLOCKS ARE TO EXTEND TO UNDISTURBED GROUND.
2. INCREASE THRUST BLOCK AREA BY 50% IN SAND.
3. WRAP ALL FITTINGS WITH 8-MIL POLYETHYLENE ENCASEMENT.
4. CONCRETE SHALL NOT COME INTO CONTACT WITH PIPE, VALVES, OR FITTINGS.
5. ALL THRUST BLOCKS ARE REQUIRED TO BE FORMED ON THE SIDES WITH SUITABLE MATERIAL AND THE BACK AGAINST UNDISTURBED EARTH.
6. CONTRACTOR SUPPLIES ALL PARTS.
7. ALL CONSTRUCTION AND MATERIALS SHALL MEET THE CITY OF OTHELLO'S DESIGN STANDARDS AND BE APPROVED BY THE CITY.

D:\WATER-2020\2021-DETAILS\DETAIL-B-12-2021

<p>CITY OF OTHELLO STANDARD DETAILS WET TAP CONNECTION DETAIL B-12</p>		#1	November, 2014	
		#2	June, 2016	
		#3	March, 2021	
		REVISION #	DATE	

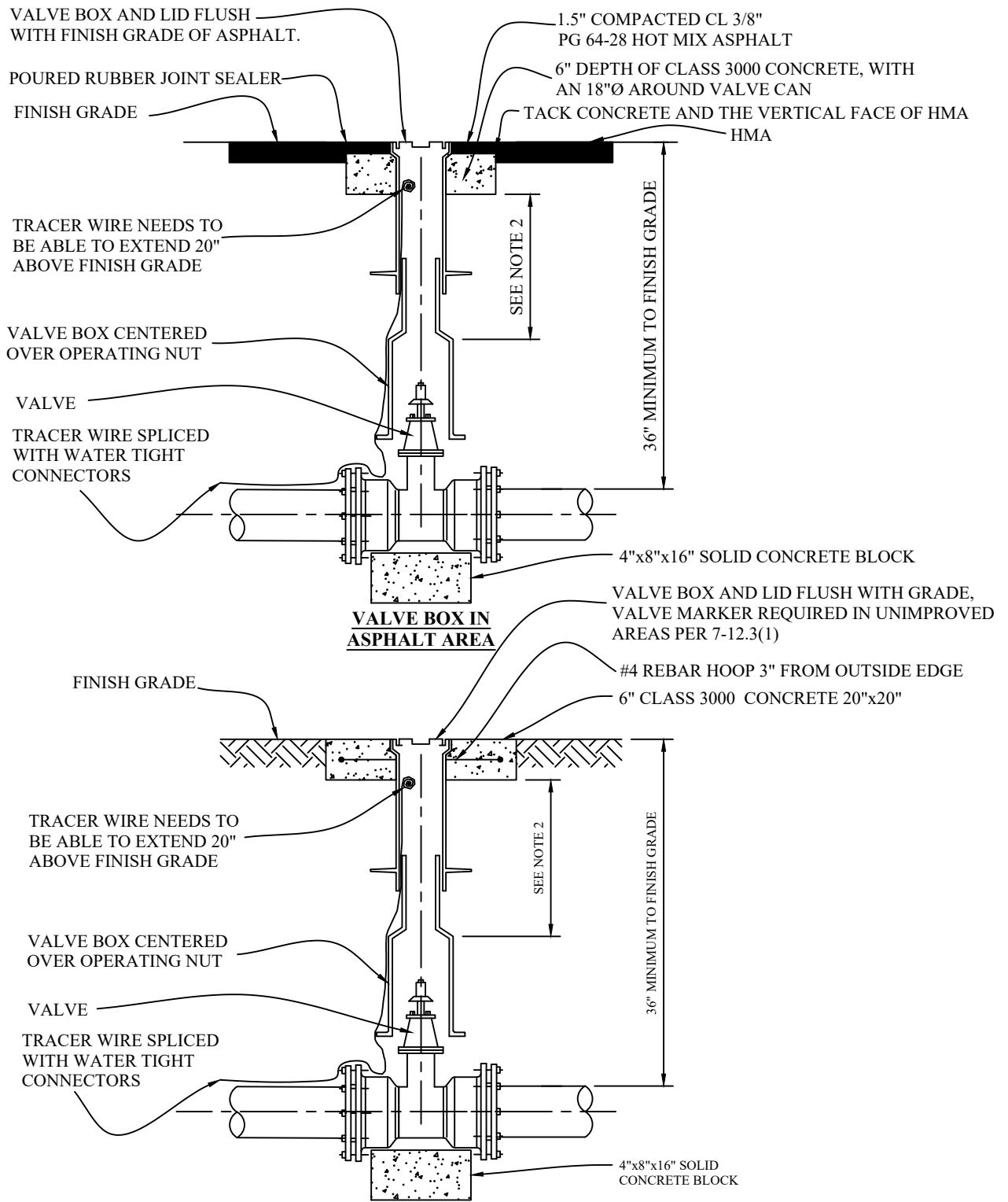

NOTES:

1. EACH VALVE SHALL BE PROVIDED WITH ADJUSTABLE CAST IRON VALVE BOX OF 5" INSIDE DIAMETER. VALVE BOXES SHALL HAVE A TOP SECTION WITH A 16" MIN. LENGTH. THE VALVE BOX SHALL BE TYLER #6855 OR CITY APPROVED.
2. 18" MINIMUM, 24" MAXIMUM FOR OPERATOR NUT. EXTENSION MAY BE REQUIRED.
3. ALL CONSTRUCTION AND MATERIALS SHALL MEET THE CITY OF OTHELLO'S DESIGN STANDARDS AND BE APPROVED BY THE CITY.
4. VALVE EXTENSION REQUIRED IF NUT IS GREATER THAN 40" FROM FINISH GRADE.
5. VALVE BOXES IN UNIMPROVED AREAS REQUIRE VALVE MARKERS, PER 7-12.3(1)

CITY OF OTHELLO
STANDARD DETAILS
VALVE BOX ADJUSTMENT DETAIL
DETAIL B-13

#1	November, 2014
#2	June, 2016
#3	March, 2021
REVISION #	DATE



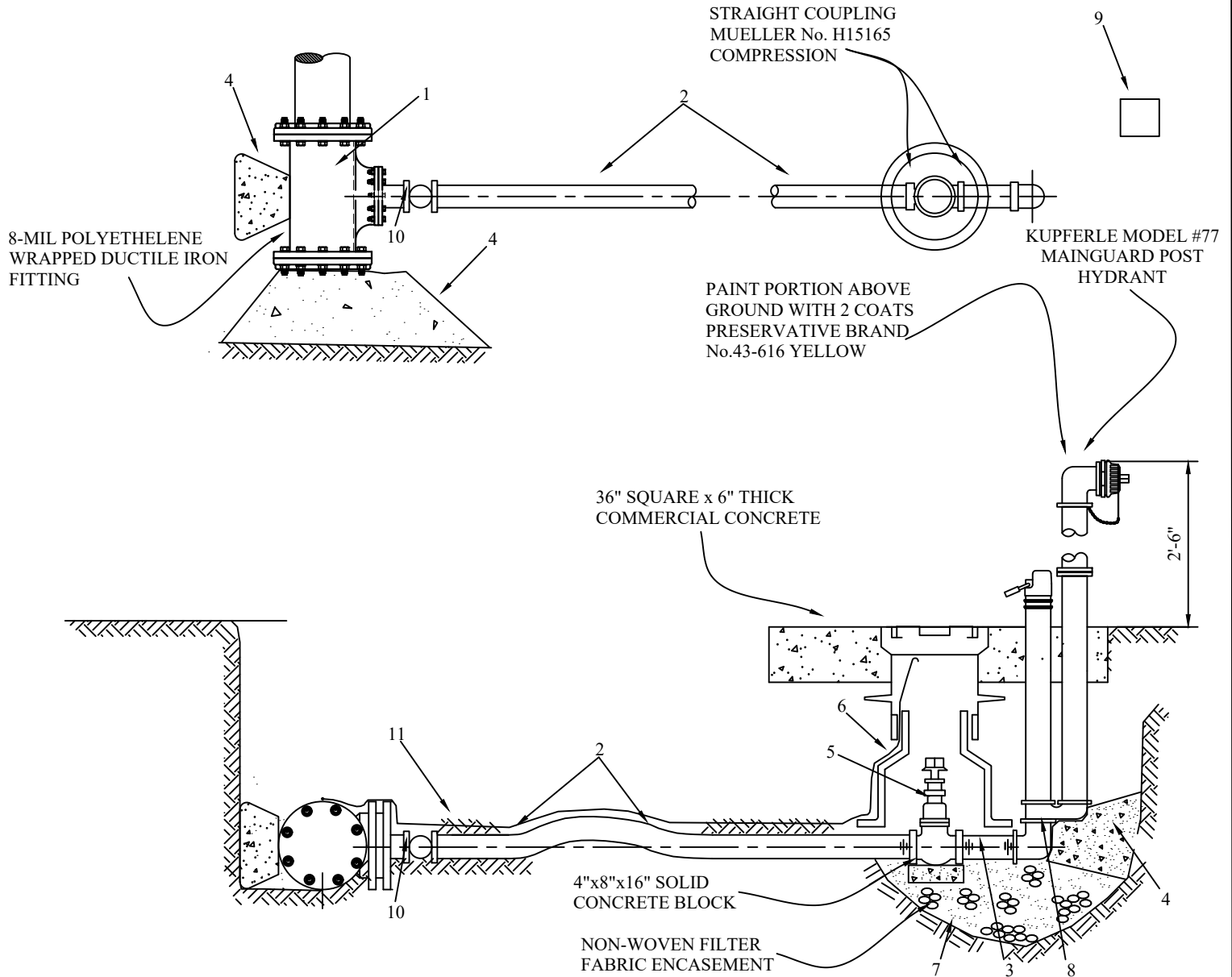

NOTES:

1. MJxMJx6"FL D.I. TEE WITH REDUCING FLANGE TAPPED 2" AND MJ PLUG
2. 2" TYPE "K" COPPER
3. 2" GALVANIZED IRON PIPE
4. CONCRETE THRUST BLOCK
5. 2" AWWA RESILIENT SEAT GATE VALVE THDxTHD WITH OPERATING NUT
6. CAST IRON VALVE BOX, TYLER #6855
7. 1/4 CUBIC YARD WASHED GRAVEL POCKET
8. 2" BRASS STREET "L"
9. VALVE MARKER POST
10. BALL VALVE, FB 500-7 CORP STOP
11. TRACER WIRE, 10 GA

GENERAL NOTES:

1. TURN NOZZLE TOWARDS ROADSIDE DITCH.
2. INSTALL DIELECTRIC COUPLINGS AT DISSIMILAR METALS.
3. TEMPORARY BLOW-OFFS INSTALLED FOR FLUSHING WATER MAIN SHALL BE SIZED TO PROVIDE 2.5fps VELOCITY IN MAIN LINE.
4. WRAP ALL DUCTILE IRON FITTINGS WITH 8-MIL POLYETHYLENE ENCASUREMENT.
5. ALL CONSTRUCTION AND MATERIALS SHALL MEET THE CITY OF OTHELLO'S DESIGN STANDARDS AND BE APPROVED BY THE CITY.
6. CITY WILL REQUIRE BOLLARDS

D:\WATER-2020\2021-DETAILS\DETAIL-B-14-2021

CITY OF OTHELLO
STANDARD DETAILS
END-LINE BLOW OFF ASSEMBLY
DETAIL B-14

#1	November, 2014
#2	June, 2016
#3	March, 2021
REVISION #	DATE



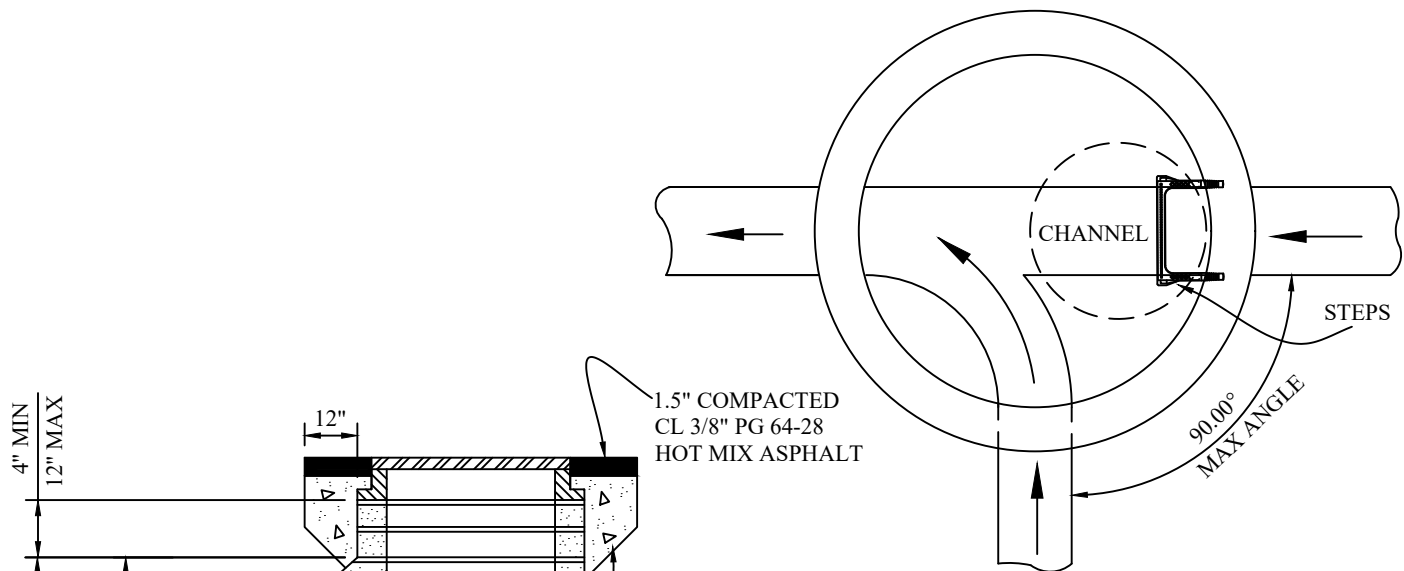

TOP VIEW

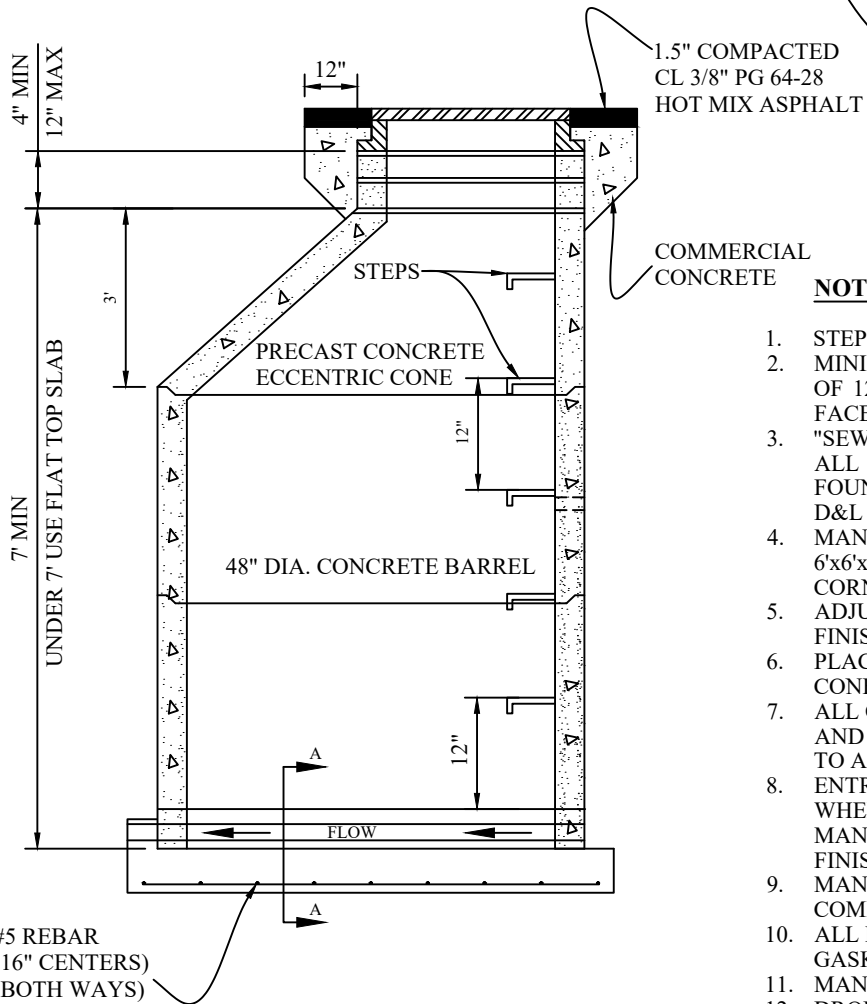

NOTES:

1. STEPS TO BE INSTALLED OVER UP STREAM SIDE OF MH.
2. MINIMUM OF 4" ADJUSTMENT RING WITH A MAXIMUM OF 12" OF ADJUSTMENT. PLASTER INSIDE AND OUTSIDE FACE WITH 1/2" THICK NON-SHRINK GROUT.
3. "SEWER" AND "CITY OF OTHELLO" SHALL BE CAST IN ALL LIDS. FRAMES SHALL BE MODEL A-2000-R1 BY D&L FOUNDRY AND COVERS SHALL BE MODEL A-2000-25 BY D&L FOUNDRY.
4. MANHOLES NOT IN ASPHALT SHALL BE CENTERED IN A 6'x6'x6" CONCRETE PAD AT FINISH GRADE. SLOPE CORNERS DOWN IN GRAVEL STREETS.
5. ADJUST MANHOLE LIDS IN ASPHALT TO 1/4" BELOW FINISH GRADE.
6. PLACE FLEXIBLE GASKET BETWEEN BARREL SECTIONS, CONE, AND ADJUSTMENT RINGS.
7. ALL OPEN JOINTS AND PICK HOLES SHALL BE FILLED AND SEALED WITH NON-SHRINK GROUT AND FINISHED TO A SMOOTH SURFACE OUTSIDE AND INSIDE.
8. ENTRY COUPLINGS OR SAND COLLARS REQUIRED WHERE SEWER MAINS, ENTER AND EXIT THE MANHOLE. SEAL WITH NON-SHRINK GROUT AND FINISHED TO A SMOOTH SURFACE, OUTSIDE AND INSIDE.
9. MANHOLE BASE SHALL BE ON UNDISTURBED OR COMPACTED EARTH.
10. ALL MANHOLES, STEPS, RING AND COVER, AND GASKETS SHALL BE, PER SECTION 9-05.50(2).
11. MANHOLE SHALL BE SET PLUMB.
12. DROP OF GRADE THROUGH MANHOLE SHALL BE 0.10' UNLESS OTHERWISE NOTED.
13. ALL CONSTRUCTION AND MATERIALS SHALL MEET THE CITY OF OTHELLO'S DESIGN STANDARDS AND BE APPROVED BY THE CITY.
14. LADDER LOCATION SUBJECT TO CHANGE IN FIELD APPLICATION.

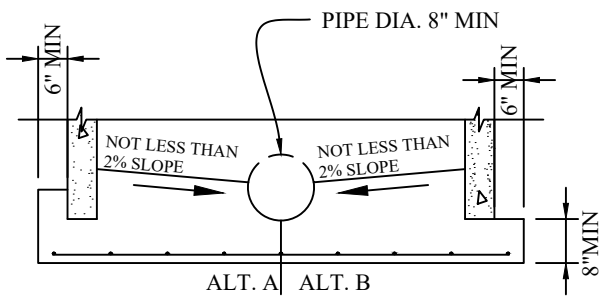

SECTION A-A

BASE CONSTRUCTION ALTERNATIVES

- ALT. A: BASE & INVERT IN SINGLE POUR
- ALT. B: POUR BASE, SET MANHOLE, THEN POUR INVERT
- ALT. C: PRECAST CONCRETE BASE & INVERTS

D:\SANITARY-SEWER-2020\DETAILS-2021\DETAIL-C-1

CITY OF OTHELLO
STANDARD DETAILS
SEWER MANHOLE
DETAIL C-1

#1	November, 2014
#2	June, 2016
#3	March, 2021
REVISION #	DATE



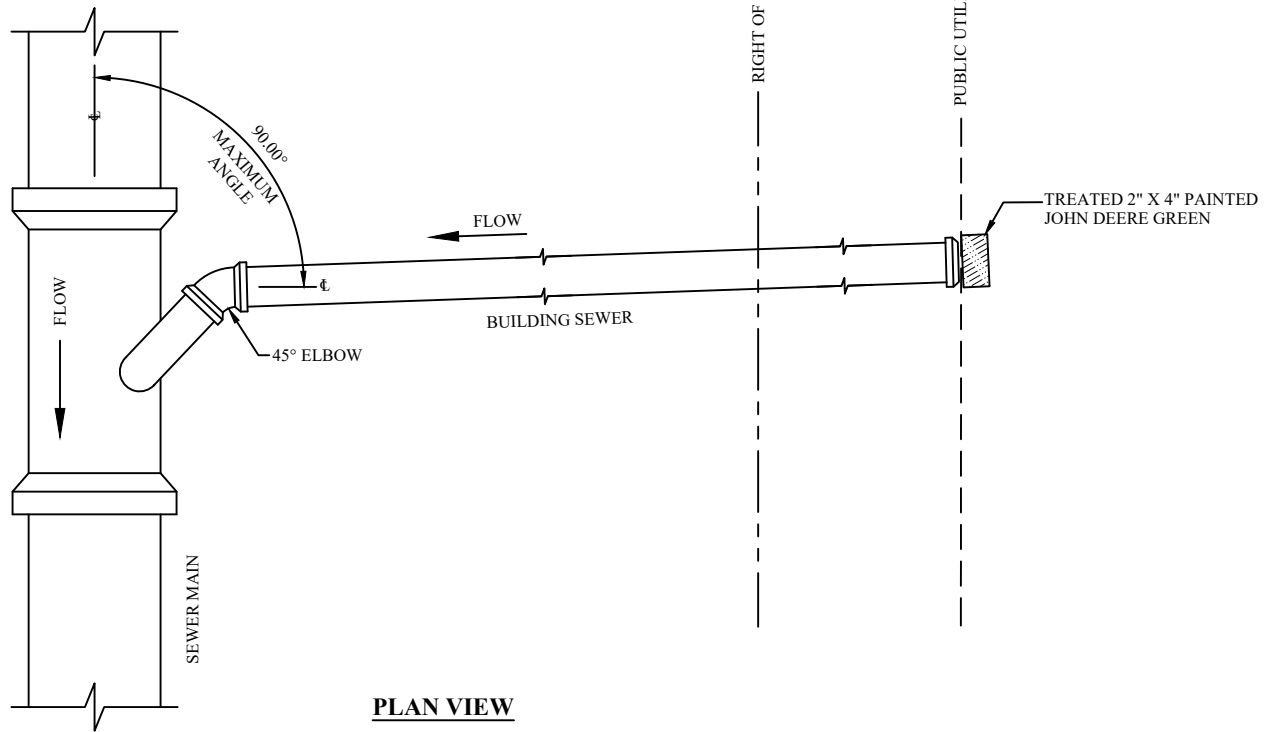

PLAN VIEW

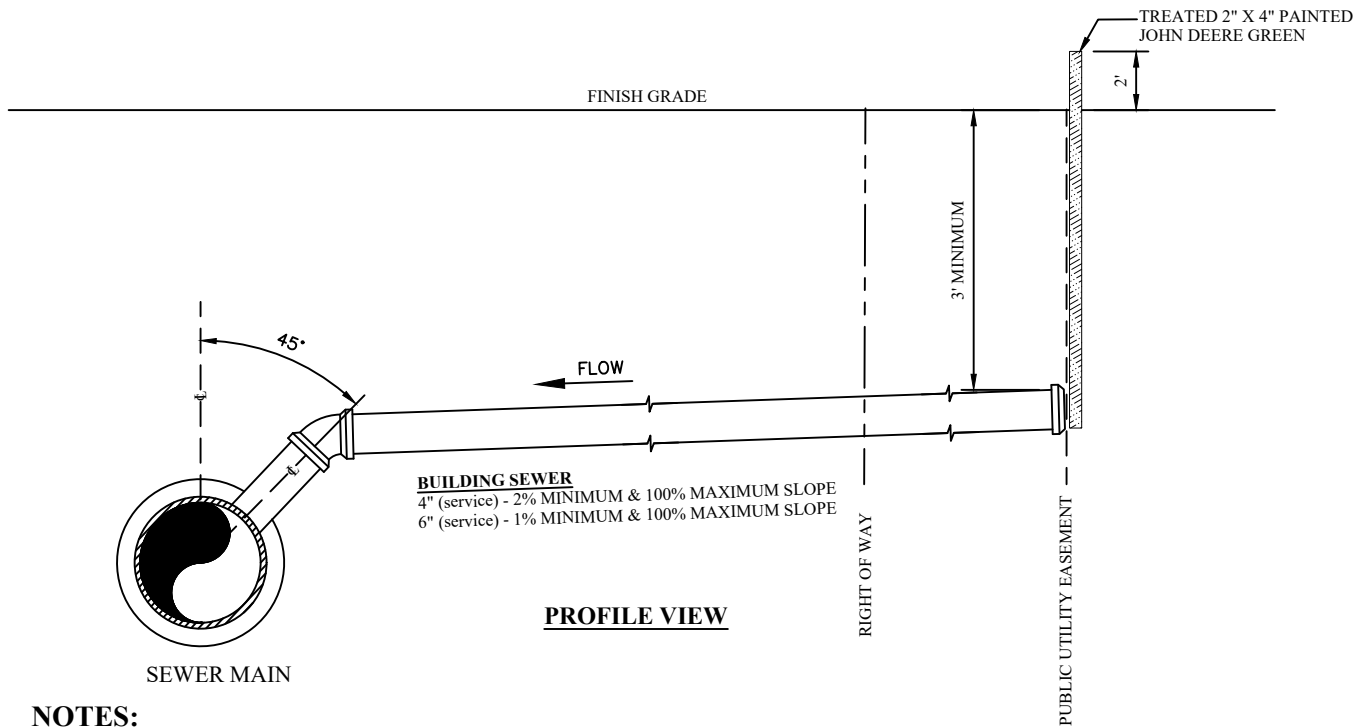

PROFILE VIEW

NOTES:

1. IN-LINE GASKETED WYE SEWER FITTING SHALL BE USED ON NEWLY INSTALLED MAINS. GASKETED WYE SEWER SADDLE WITH STAINLESS STEEL CLAMPS SHALL BE USED ON EXISTING SEWER MAINS.
2. THE END OF THE SERVICE LINE SHALL HAVE GASKET CAPPED.
3. A TREATED 2" X 4" (WOOD) SHALL BE PLACED FROM GASKET CAP TO 2' ABOVE FINISH GRADE 2" X 4" SHALL BE PAINTED JOHN DEERE GREEN, TO MARK END OF SEWER SERVICE.
4. SS SHALL BE STAMPED IN FACE OF CURB TO MARK WHERE SEWER SERVICE CROSSES UNDER THE CURB.
5. BUILDING SEWER CLEANOUTS ARE NOT ALLOWED WITHIN MUNICIPAL EASEMENTS OR RIGHT OF WAY.
6. ALL CONSTRUCTION AND MATERIALS SHALL MEET THE CITY OF OTHELLO'S DESIGN STANDARDS AND BE APPROVED BY THE CITY ENGINEER.

D:\SANITARY-SEWER-2020\DETAILS-2021\DETAIL-C-2-2021

CITY OF OTHELLO
STANDARD DETAILS
SIDE SEWER
DETAIL C-2

#1	November, 2014
#2	June, 2016
#3	March, 2021
REVISION #	DATE



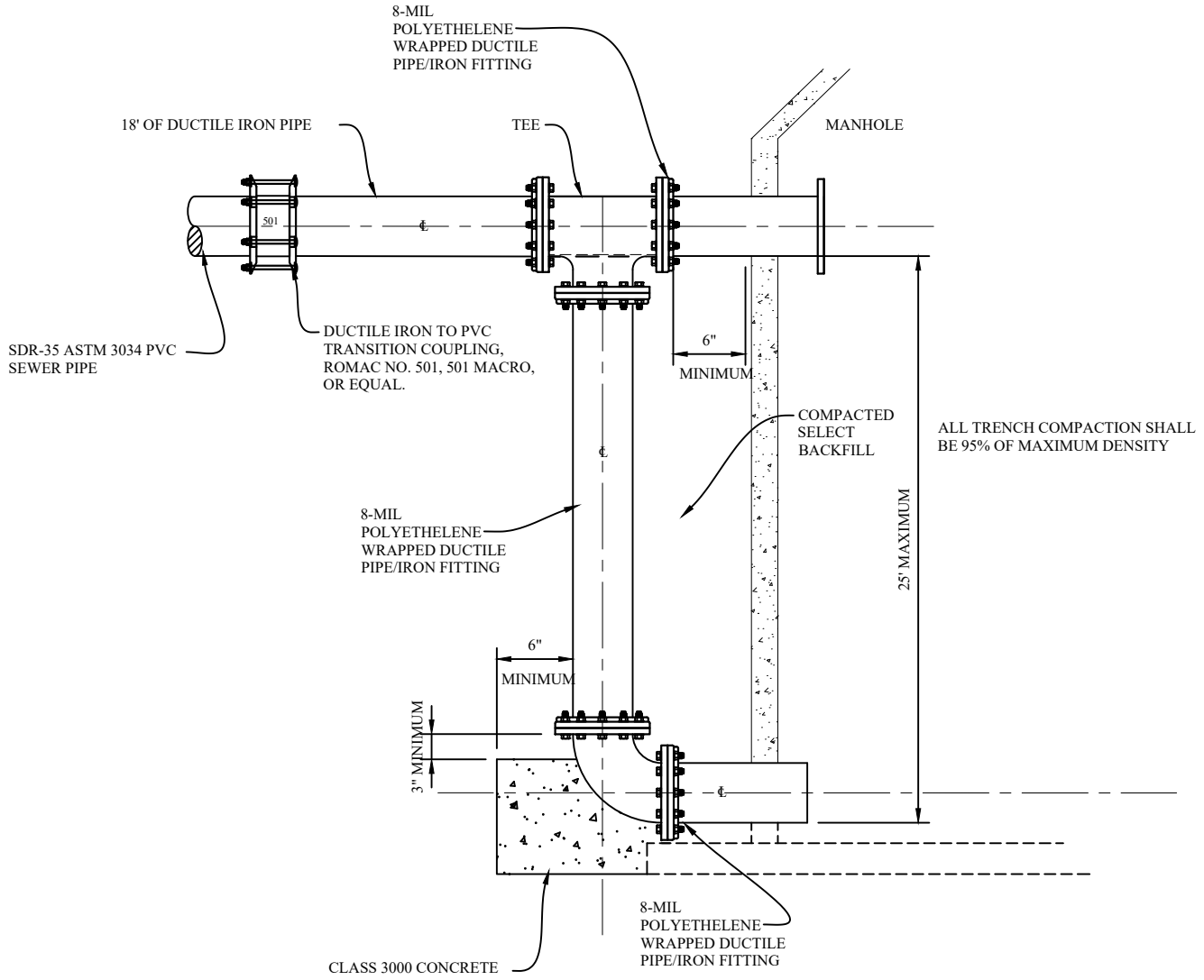

**DUCTILE IRON
OUTSIDE DROP CONNECTION**

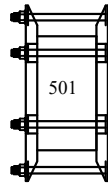

ROMAC - 501



ROMAC - 501 MACRO

NOTES:

1. ALL PIPING AND FITTINGS TO BE DUCTILE IRON.
2. MANHOLE SHALL BE CONSTRUCTED PER FIGURE C-1.
3. ALL DUCTILE IRON PIPE SHALL BE A MINIMUM OF CLASS 50.
4. WRAP ALL DUCTILE IRON FITTINGS WITH 8-MIL POLYETHYLENE ENCASEMENT
5. DROP MANHOLE CONNECTIONS SHALL NOT BE CONSTRUCTED UNLESS APPROVED BY PUBLIC WORKS.
6. ALL CONSTRUCTION AND MATERIALS SHALL MEET THE CITY OF OTHELLO'S DESIGN STANDARDS AND BE APPROVED BY THE CITY.

**CITY OF OTHELLO
STANDARD DETAILS
DROP MANHOLE CONNECTION**

DETAIL C-3

#1	November, 2014
#2	June, 2016
#3	March, 2021
REVISION #	DATE



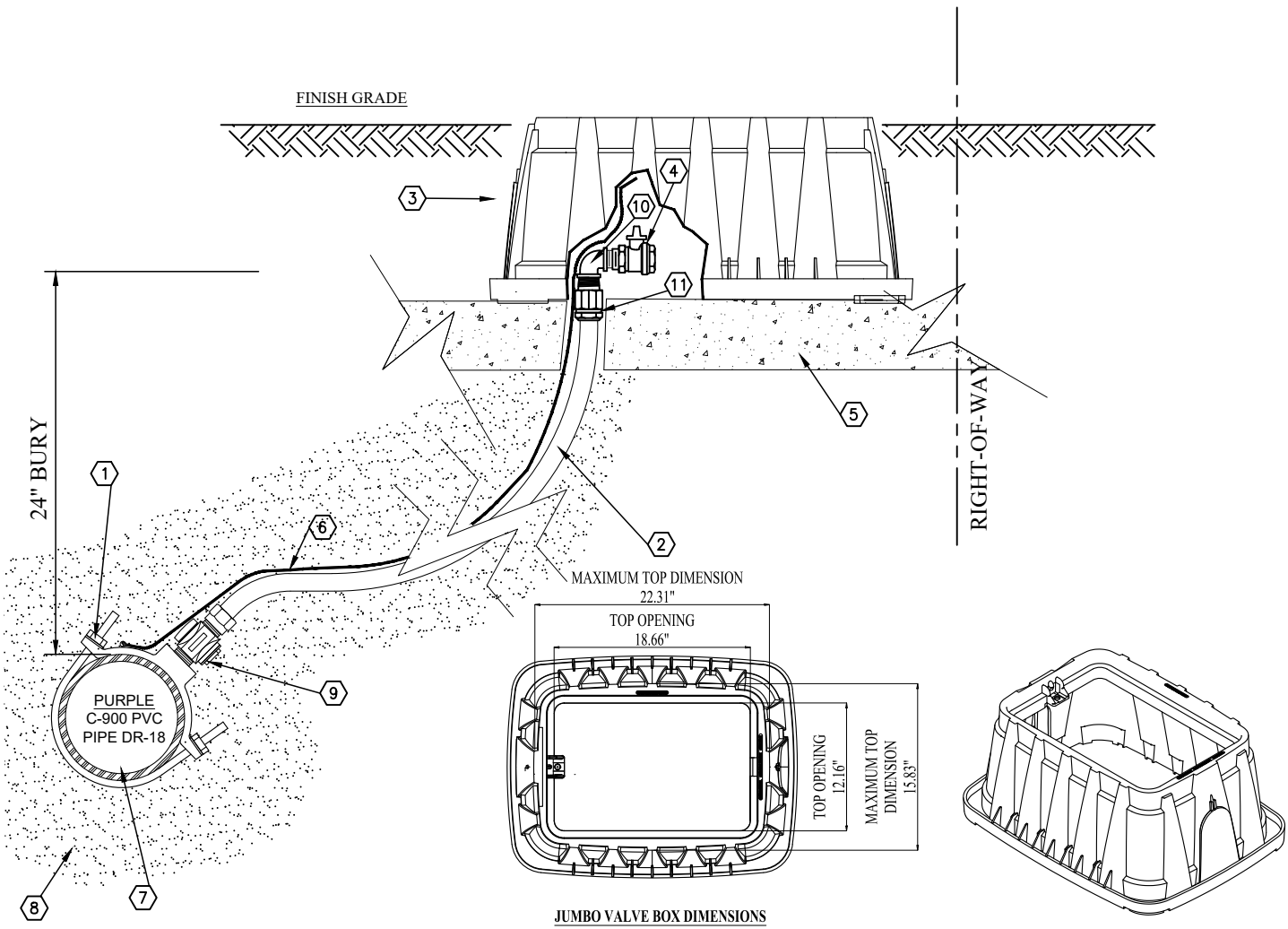

JUMBO VALVE BOX DIMENSIONS

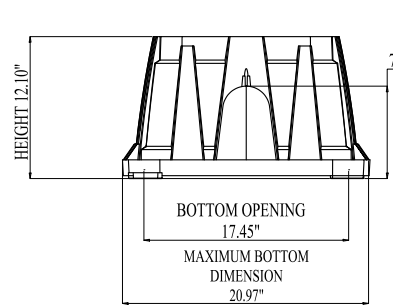
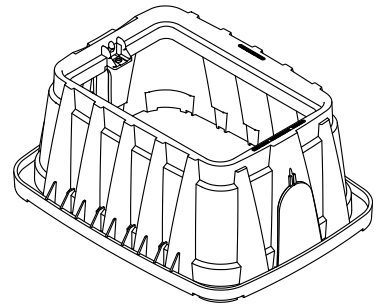
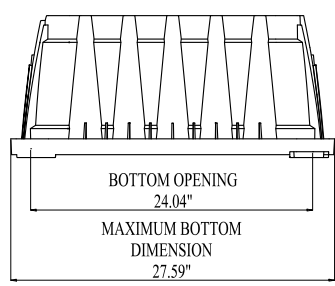

KNOCKOUT HEIGHT 7.87\"/>

NOTE:

- ① 1" ROMAC STAINLESS DOUBLE STRAP SERVICE SADDLE 202S, or approved equal.
- ② 1" HIGH DENSITY POLYETHYLENE TUBING SDR-9- CROSSLINKED POLYETHYLENE PEX-A ENGEL METHOD; PEX 5106 "AQUAPEX" RECLAIMED WATER TUBING, ASTM F-876, F-877, F-1960, F-E-84, E-119, BY UPONOR (OR APPROVED EQUAL)
- ③ FRP BOX, RAIN BIRD PVBMB BOX W/VBJMBPL LID (or approved equal). BOX AND LID SHALL BE TRAFFIC RATED WHEN INSTALLED IN TRAVELED WAYS.
- ④ 1" - FORD BALL VALVE CURB STOP WITH STOP AND WASTE BC11-444SW-NL, or approved equal.
- ⑤ 4" of CSTC
- ⑥ TRACER WIRE (PURPLE, 10 GAUGE, SOLID CORE WIRE) SHALL BE INSTALLED ON NP-MAIN AND SERVICE LINE. SECURED WITH DUCT TAPE AT 10' INTERVALS. MIN. OF 18" OF ACCESSIBLE WIRE AT THE TERMINATION IN THE SERVICE BOX.
- ⑦ PURPLE C-900 DR-18 PVC PIPE REQUIRED FOR NP MAIN
- ⑧ 6"- MIN OF SAND BEDDING
- ⑨ FORD CORP STOP/BALL VALVE FB1100-4Q WITH 1"- STAINLESS STEEL INSERT - 52, or approved equal.
- ⑩ 1" - FORD QUICK JOINT COUPLING C84-44-Q- NL WITH 1"- STAINLESS STEEL INSERT - 52, or approved equal.
- ⑪ 1" - COPPER 90° FITTING ASTM B 584 (LEAD FREE)

CITY OF OTHELLO
STANDARD DETAILS
1" NON-POTABLE SERVICE CONNECTION
DETAIL NP-1

#1	July, 2017
#2	June, 2020
#3	March, 2021
REVISION #	DATE

